

**INSTALLATION INSTRUCTIONS
AND
INSTRUCTIONS FOR CONTINUED
AIRWORTHINESS**

**Aero Twin, Inc. Deice Cycler Kit No. DT8-100
for
Cessna 208 and 208B Aircraft Equipped with Pneumatic Deice Boots**

Document No. DT8-ICA

Maintenance Manual
Airworthiness Limitations
Illustrated Parts List

LOG OF REVISIONS			
REVISIONS		PAGES REVISED AND DESCRIPTION OF REVISIONS	APPROVAL SIGNATURE
NO.	DATE		
N/C	12/31/12	Original Issue	Jason Kepler
A	8/08/14	Revised pages 2, 4-6, and 15 per ECO AT-163	<i>Jason Kepler</i>

Information in this publication is based on data available at the time of publication and may be updated, supplemented, and automatically amended by a revision or re-issuance. All such amendments become part of and are specifically incorporated within this publication. Users are urged to keep abreast of the latest amendments to this publication through information available on Aero Twin, Inc.'s website, <http://www.aerotwin.com>. The latest revision of the Instructions for Continued Airworthiness for all of Aero Twin, Inc.'s products are available for download at that website.

Table of Contents

Section	Page
Log of Revisions.....	2
Table of Contents	3
1.0 Installation and Maintenance Manual	4
1.1 Description and Operation.....	4
1.2 Initial Installation	4
1.3 Removal/ Installation.....	6
1.4 Troubleshooting	7
1.5 Pneumatic Deice System Adjustment/Test.....	11
2.0 Airworthiness Limitations.....	13
3.0 Parts List and Wiring Diagram	14

1.0 Installation and Maintenance Manual

Aero Twin, Inc. Deice Cyclor, Kit No. DT8-100

1.1 Description and Operation

The Aero Twin deice cyclor for the Cessna 208 and 208B aircraft adds to the existing pneumatic deice system an automatic cyclor, a DEICE CYC INOP annunciator, a DE-ICE CYC PWR indicator, and a three position cycle selector switch labeled BOOT CYCLE SEL. Additionally, the BOOT PRESS switch is replaced with one that is not momentary in the AUTO position. The deice cyclor control unit is located in the belly of the aircraft under the pilot's seat. The new BOOT CYCLE SEL switch is installed immediately below the BOOT PRESS switch. The DE-ICE CYC PWR indicator is installed immediately to the left of the BOOT CYC SEL switch. The deice system is activated by placing the BOOT PRESS switch in the AUTO position and the BOOT CYCLE SEL switch in either the 1 minute or 3 minute position. The cyclor will automatically activate the existing Cessna three-cycle timer once every minute or three minutes, depending on the interval selected. To bypass the cyclor and activate the boots between cycles, or to reset the system, the BOOT CYCLE SEL switch is momentarily held in the BYPASS/RESET position, and released. Alternatively, both the new cyclor and Cessna's three-cycle timer can still be bypassed by momentarily holding the BOOT PRESS switch in the MANUAL position and releasing.

1.2 Initial Installation

The following are instructions for the initial installation of the Deice Cyclor system.

NOTE: Wire numbers HD 62 through HD 70 are trimmed to length during installation. Each wire must be labeled with the appropriate wire number using the pre-printed shrink tube provided in the kit. These labels must be placed within 3 inches of the trimmed end.

Before installation, determine which annunciator panel pin will be used for warning annunciator using the criteria on wiring diagram ATI-30-10-01. If pin 18 or 47 is to be used, P/N DT8-65-WIRE wiring harness must be used. If pin 29 or 33 is to be used, P/N DT8-62-WIRE wiring harness must be used.

1. Remove the pilot seat per Cessna Maintenance Manual chapter 25-10-00.
2. Remove the floor access panel below the pilot seat between FS 143.0 and 158.0.
3. Place cyclor, ATI-ICE-CYC, in access hole on the aircraft skin, with the long edge running longitudinally in the aircraft, and the electrical connector on the forward end. Place front edge of mounting flange 3.0 to 4.0 inches aft of the bulkhead at FS 143.0, and the inboard side 1.0±0.5 inches outboard of the inboard pilot seat rail longeron. Mark location of the four attachment holes on the cyclor onto the skin.
4. Verify that the attachment holes do not interfere with other existing structure, including the cargo pod, and drill holes in skin using a #7 bit. If holes will interfere, adjust position of the cyclor within the tolerances of the above positioning dimensions.
5. Deburr all holes and attach cyclor using four each AN525-10R8 screws, NAS1149F0332P washers, and MS21044N3 nuts. Position screw heads on outside of aircraft belly. Place washers under nuts on the cyclor mounting flange.

6. Connect wire harness to cycler. If P/N DT8-62-WIRE wiring harness is used, the included relay, P/N M39016/6-207, must be installed. To install relay in aircraft, position relay on longeron inboard of cycler, 1.5 – 2.0 inches forward of the cycler. Verify that the relay does not interfere with existing structure or flight controls. Match drill relay mounting tab holes into longeron using a #30 bit. Deburr holes and attach relay using two each MS35206-214 screws and MS21044N04 nuts.
7. Route wire harness through bulkhead and longeron lightening holes to come up through floor in the area of the GCU just forward of the circuit breaker panel. More floor access panels will be required to be removed to accomplish this, including the side kick panel forward of the circuit breaker panel. Route and secure wire harness in accordance with the best practices described in Cessna Wiring Manual Chapter 20 and AC 43.13-1B Chapter 11.
8. Tag and mark existing wires HD 2, HD 3, HD 4, and HD 21 where they connect to the deice BOOT PRESS switch.
9. Remove all wires from the deice BOOT PRESS switch and replace switch in panel with a MS35058-31 switch oriented so the momentary position is down.
10. Connect HD 2, HD 4, and HD 21 to the new BOOT PRESS switch (S71) as shown in wiring diagram ATI-30-10-01.
11. Locate and drill a 0.368 inch diameter hole (U bit) for the new DE-ICE CYC PWR indicator, centered 1.5 inches below the center of the BOOT PRESS switch.
12. Align BOOT CYCLE SEL switch placard with new indicator hole and match drill a ½ inch diameter hole for the new BOOT CYCLE SEL switch. Using a 1/8 inch bit, drill a key hole centered 3/8 inch above the new ½ inch hole. Deburr the new holes.
13. Using DP-190, glue BOOT CYCLE SEL switch placard to panel, with switch and indicator holes in placard centered on new panel switch and indicator holes.
14. Install BOOT CYCLE SEL switch, P/N MS27407-5, in newly created hole, with momentary position up. Connect HD 3 to pin 4, the jumper between pins 2 and 6, and new HD 61 wire between the two new switches.
15. Install DE-ICE CYC PWR indicator, P/N 45RNG18-2112T3, in newly created hole. Trim HD 69 and HD 70 to length and connect to indicator using 18RAD-18277 terminals. Connect ring terminal of HD 70 to chassis ground.
16. Run wires HD 62, HD 63, and HD 68 from the cycler wire bundle to the BOOT CYCLE SEL switch. Trim the wires to length, crimp on ring terminals, P/N RA18-6, and install on switch.
17. Remove annunciator panel per Cessna Maintenance Manual Chapter 31-50-00.
18. Run wires HD 65, HD 66, and HD 67 from cycler wire bundle to annunciator panel connector.
19. Remove HD 16 from pin 36 of annunciator panel connector and cut off the terminal.
20. Using P/N 2RA18, splice HD 16 to HD 65 (cut to length), using a piece of shrink tubing to cover the splice.
21. Cut HD 66 and HD 67 to length and crimp on P/N S-2341-1 pins. Install HD 66 in annunciator panel connector pin 36. Install HD 67 in pin determined using criteria on wiring diagram ATI-30-10-01.
22. In the annunciator location associated with the pin where HD 67 was installed, install DEICE CYC INOP label with an amber lens.
23. Reinstall the annunciator panel per Cessna Maintenance Manual Chapter 31-50-00.
24. Run HD 64 to grounding block J66, trim to length, and crimp on P/N S-2099-4 pin. Install HD 64 in grounding block J66, pin P. (If pin P is not available, use an available grounding block pin.)

25. Ensure all new wiring is properly secured per Cessna Maintenance Manual Chapter 20 and AC 43.13-1B Chapter 11.
26. Reinstall access panels and pilot seat per Cessna Maintenance Manual.
27. Add 2.5 pounds to the aircraft empty weight and balance at FS 150.5.
28. Perform electrical and functional tests in section 1.4.1 of this document.
29. Include latest approved revision of Airplane Flight Manual Supplement DT8-AFMS with aircraft POH/AFM.
30. Complete FAA Form 337 showing installation of this STC and return aircraft to service.

1.3 Removal / Installation

1.3.1 Removal of Pneumatic Deice Cyclers:

1. Remove pilot seat and floor access panel under seat between FS 143 and 158. See Cessna maintenance manual chapter 25-10-00.
2. Ensure airplane electrical power is OFF.
3. Disconnect electrical connector from cyclers.
4. Remove four each AN525-10R8 screws, MS21044N3 nuts, and NAS1149F0332P washers securing the cyclers to the belly skin and remove cyclers from airplane.

1.3.2 Install Pneumatic Deice Cyclers:

1. Align cyclers with holes in belly skin.
2. Install four each AN525-10R8 screws, MS21044N3 nuts, and NAS1149F0332P washers to secure cyclers.
3. Connect electrical connector to cyclers.
4. Reinstall floor access panel and pilot seat. See Cessna maintenance manual chapter 25-10-00.

1.4 Troubleshooting

1.4.1 General:

The following troubleshooting charts replace the troubleshooting charts found in Cessna's 208 maintenance manual chapter 30-10-00:

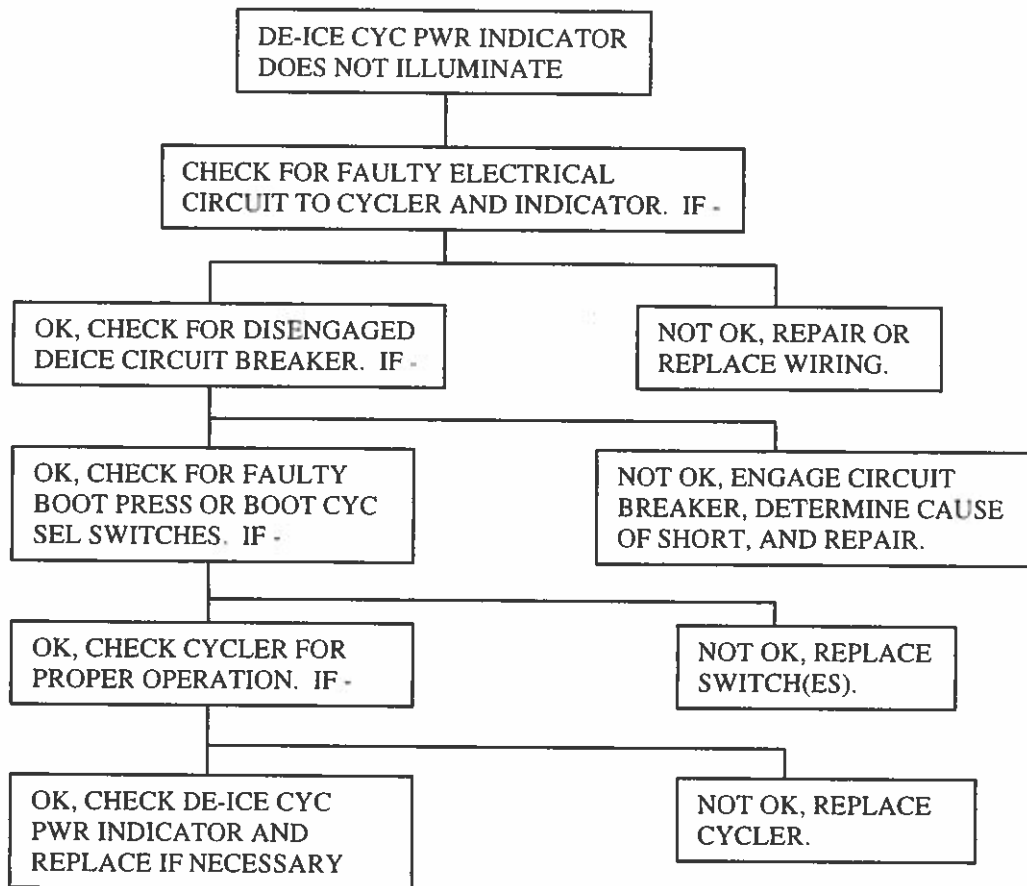

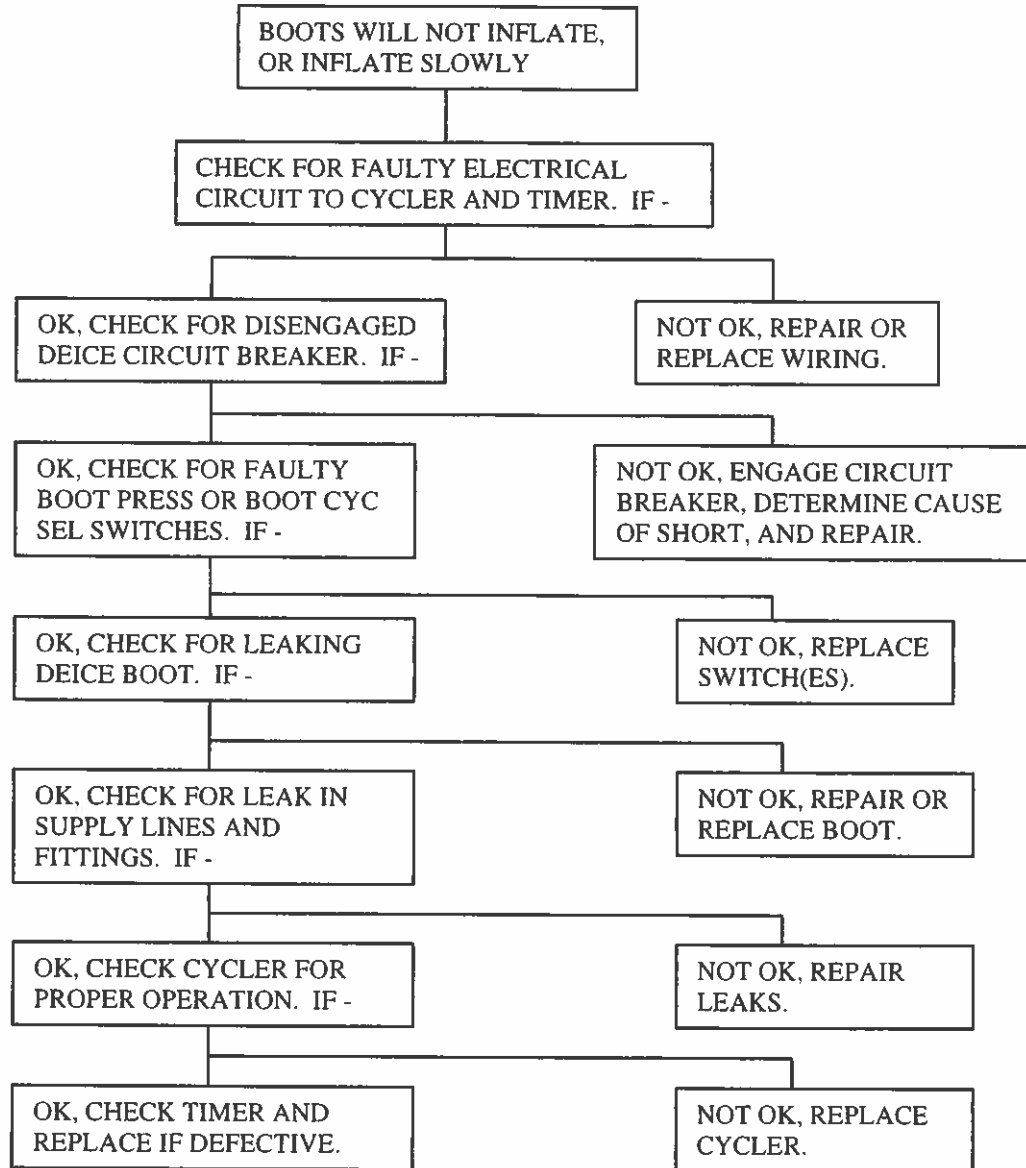

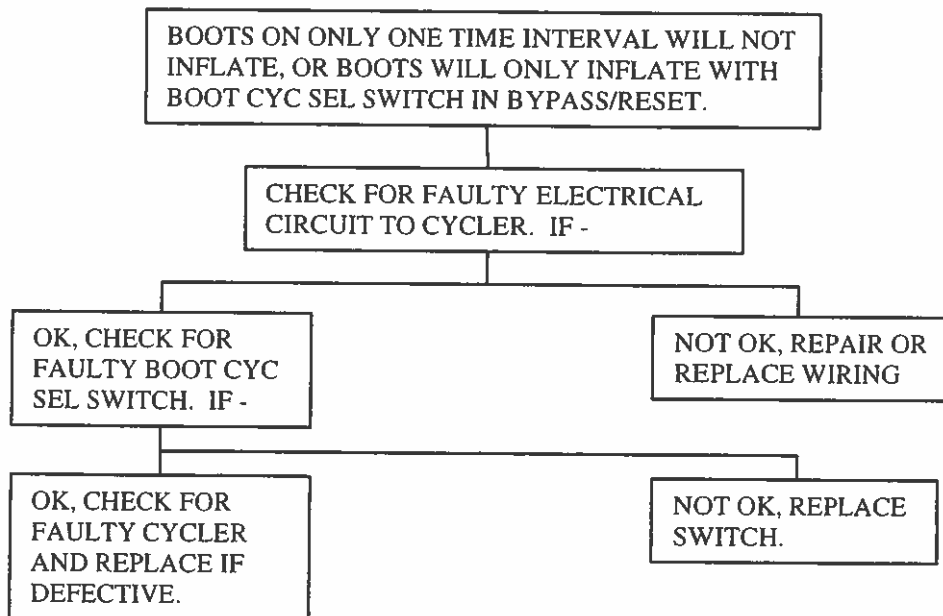
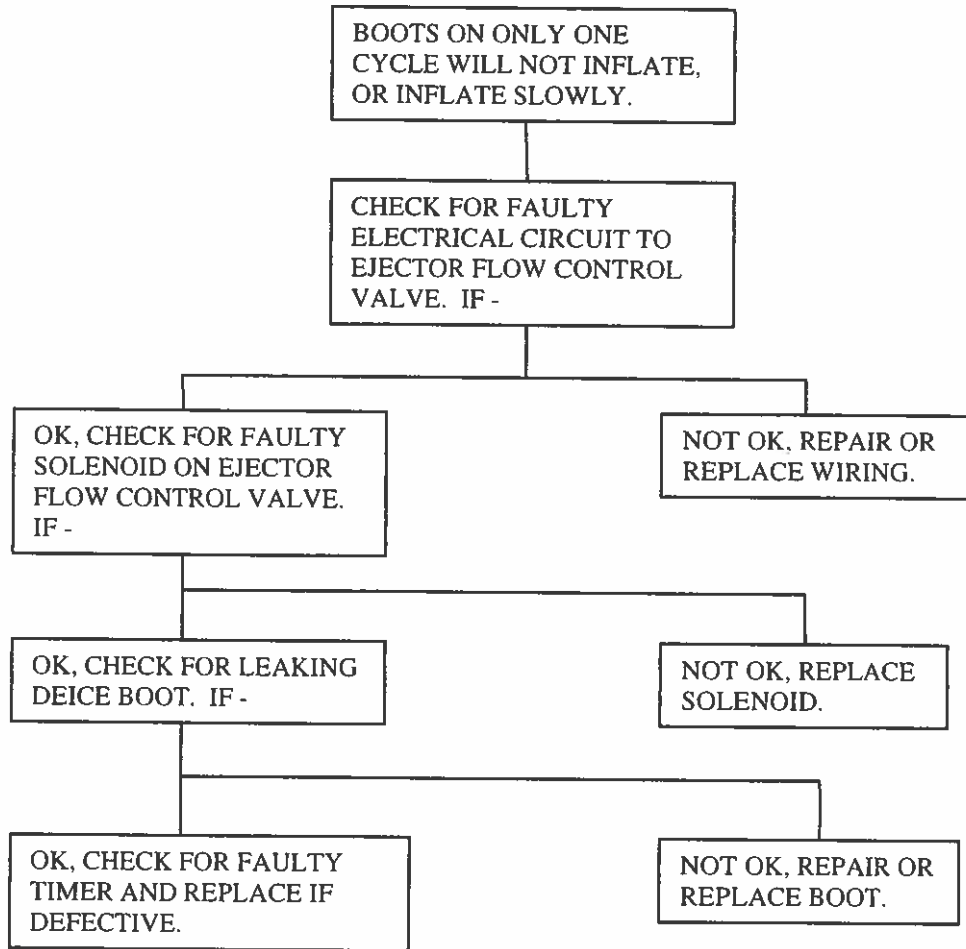

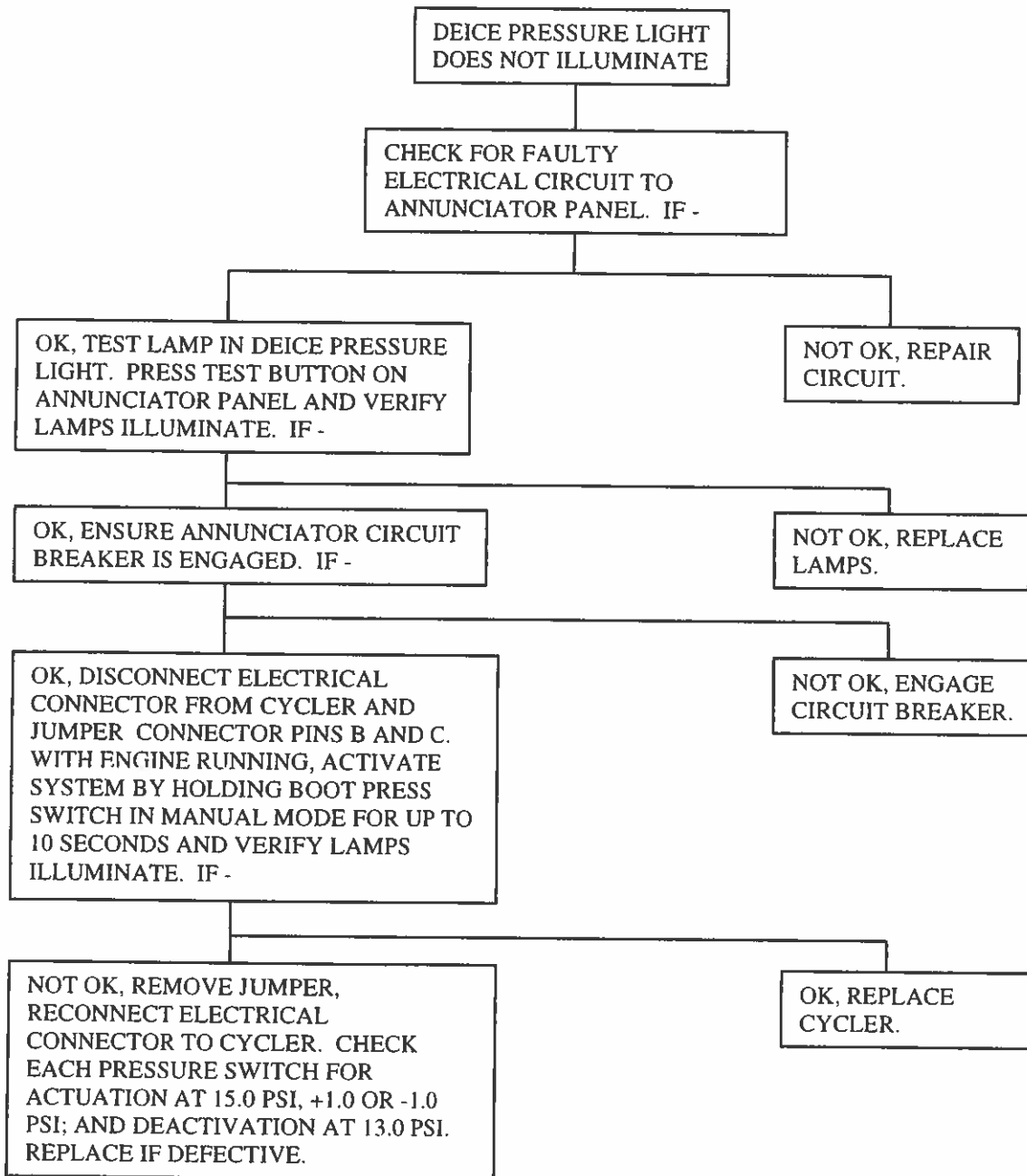

1.5 Pneumatic Deice System Adjustment/Test

1.5.1. Modified Cessna System Adjustment/Test Procedures:

The following are some of the adjustment/test procedures of the pneumatic deice system listed in Cessna's 208 maintenance manual chapter 30-10-00, as modified by the Aero Twin deice cyclor. Continue to reference Cessna's manual for pneumatic surface deice system maintenance procedures unaffected by the cyclor installation.

A. Electrical Test.

- (1) Engage deice boot circuit breaker.
- (2) Place deice BOOT PRESS switch in OFF (center) position.
- (3) Position battery master switch to ON.
- (4) Press annunciator panel test switch to check light circuit and lamps.
- (5) With engine not running, position deice BOOT PRESS switch to AUTO (up) position and observe DE-ICE CYC PWR indicator illuminates. Observe DEICE CYC INOP annunciator comes on within four minutes.
- (6) Position deice BOOT PRESS switch to OFF (center) position and observe DE-ICE SYS PWR indicator and DEICE CYC INOP annunciator extinguishes.
- (7) With engine running, position BOOT CYC SEL switch to 3 MIN (down) and deice BOOT PRESS switch to AUTO (up) position and verify following conditions are exhibited sequentially.
 - a) Boots on vertical fin and horizontal stabilizers inflate for a period of six seconds.
 - b) Boots on inboard wings inflate for a period of six seconds.
 - c) Boots on outboard wings and wing struts inflate for a period of six seconds.
 - d) Cycle repeats after a 150 to 180 second interval.
- (8) Verify that deice pressure light, located on annunciator panel, remains illuminated for a period of six seconds during each of the three sequential boot cycles and extinguishes momentarily between cycles.
- (9) Position BOOT CYC SEL switch to 1 MIN (center) and observe a proper deice boot cycle on approximately a one minute interval cycle.
- (10) Momentarily position the BOOT CYC SEL switch to BYPASS/RESET (up) position and verify that a proper deice boot cycle commences immediately.
- (11) Position and hold deice BOOT PRESS switch to manual (down) and verify all boots inflate simultaneously and deice pressure light illuminates.
- (12) Position wing light switch to ON (up) and verify ice detector light is illuminated.
- (13) Shut off engine.

B. Pneumatic Deice System Timer Test.

- (1) Check for system voltage between pins 3 and 1 of deice timer with BOOT PRESS switch OFF. Verify voltage is indicated.
- (2) Check for system voltage between pins 6 and 1 of deice timer with BOOT PRESS switch ON and BOOT CYC SEL switch held in BYPASS/RESET (up) position. Verify voltage is indicated.
- (3) Check for system voltage between pins 8 and 1 of deice timer with BOOT PRESS switch ON and BOOT CYC SEL switch held in BYPASS/RESET (up) position. Verify voltage is indicated as timer cycles.

- (4) Check for system voltage between pins 9 and 1 of deice timer with BOOT PRESS switch OFF and BOOT CYC SEL switch held in BYPASS/RESET (up) position. Verify voltage is indicated as timer cycles.
- (5) Check for system voltage between pins 7 and 1 of deice timer with BOOT PRESS switch OFF and BOOT CYC SEL switch held in BYPASS/RESET (up) position. Verify voltage is indicated as timer cycles.
- (6) If system voltage is not present between any of pins tested, timer is defective and must be replaced. Refer to Cessna 208 maintenance manual for Pneumatic Deice Timer Removal/Installation.
- (7) Place boot press switch in OFF position.

1.5.2 Deice Cycler Test

A cycler test box is available for purchase from Aero Twin. Alternatively one can be built using the wiring diagram shown here:

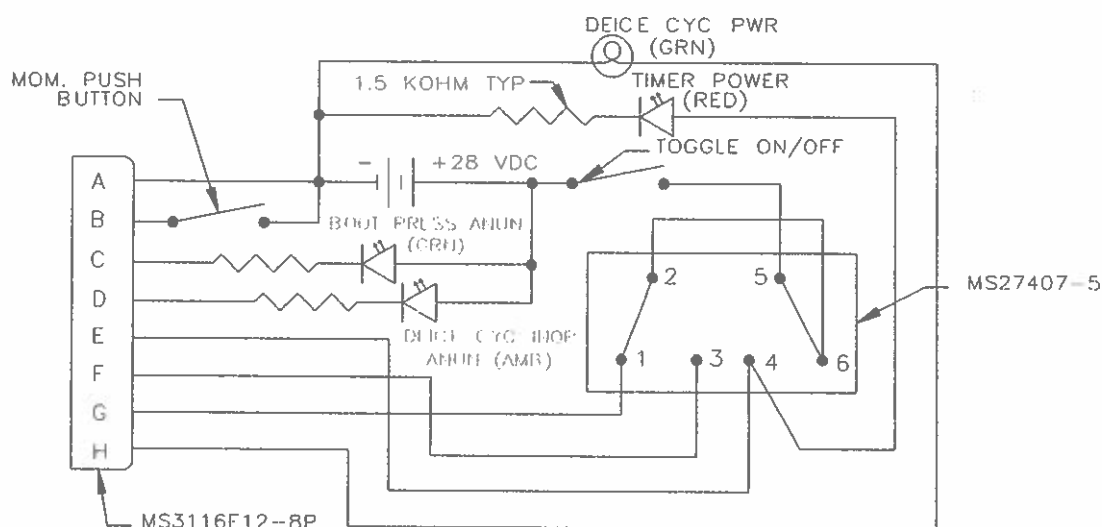

Deice Cycler Test Box Wiring Diagram

A. Pneumatic Deice System Cycler Test Using Test Box.

- (1) Gain access to the deice cycler in the belly under the pilot's seat.
- (2) With all electrical power off in the aircraft, disconnect connector from the cycler and connect the connector on the test box to the cycler.
- (3) With selector switch on test box centered, turn on test box toggle switch.
- (4) Observe green DEICE CYC PWR LED illuminates.
- (5) Observe red TIMER POWER LED illuminates for 5 seconds on a one minute interval.
- (6) Observe amber DEICE CYC INOP ANUN LED illuminates between 3.5 and 4 minutes after turning on the test box.
- (7) Push momentary push button and observe green BOOT PRESS ANUN LED illuminates and amber DEICE CYC INOP ANUN LED extinguishes.
- (8) Release momentary push button and observe green BOOT PRESS ANUN LED extinguishes.
- (9) Position test box selector switch away from the momentary position.
- (10) Observe red TIMER POWER LED illuminates for 5 seconds on a three minute interval.

- (11) Position test box selector switch in momentary position.
- (12) Observe red **TIMER POWER LED** illuminates and green **DEICE SYS PWR LED** extinguishes until releasing the selector switch.
- (13) Turn off test box toggle switch and observe all LED's extinguished.
- (14) Push momentary push button and observe green LED illuminates while button is held.
- (15) If system does not behave as described, cyclor is defective and must be replaced. Refer to removal/installation instructions in section 1.2.
- (16) Reconnect aircraft electrical connector to cyclor.
- (17) Replace access panel(s) and pilot's seat as required.

B. Pneumatic Deice System Cyclor Test Without Test Box.

- (1) Gain access to the deice cyclor in the belly under the pilot's seat.
- (2) With all electrical power off in the aircraft, disconnect connector from the cyclor.
- (3) Apply ground to pin A on cyclor.
- (4) Verify pin D is open.
- (5) Apply system voltage to pin G. Verify system voltage at pin E for five seconds on one minute cycle and at pin H continuously.
- (6) Remove voltage from pin G and apply system voltage to pin F. Verify system voltage at pin E for five seconds on three minute cycle and at pin H continuously.
- (7) Keeping system voltage on pin F, look for a continuous ground on pin D after ~210 seconds.
- (8) Keeping system voltage on pin F, apply voltage to pin C and ground to pin B.
- (9) Observe an open circuit at pin D.
- (10) Remove all voltage and grounds from connector.
- (11) Check for good continuity between pins B and C.
- (12) If system voltage or ground is not present between any of pins tested, cyclor is defective and must be replaced. Refer to removal/installation instructions in section 1.2.
- (13) Reconnect aircraft electrical connector to cyclor.
- (14) Replace access panel(s) and pilot's seat as required.

2.0

Airworthiness Limitations

Aero Twin, Inc. Deice Cyclor, Kit No. DT8-100

The Airworthiness Limitations section is FAA approved and specifies maintenance required under paragraphs 43.16 and 91.403 of the Federal Aviation Regulations unless an alternative program has been FAA approved.

There are no airworthiness limitations for this modification.

-----End of Section 2.0 Airworthiness Limitations-----

3.0 Parts List and Wiring Diagram

Aero Twin, Inc. Deice Cycler, Kit No. DT8-100

The following is a wiring diagram and parts list for the deice cycler modification.

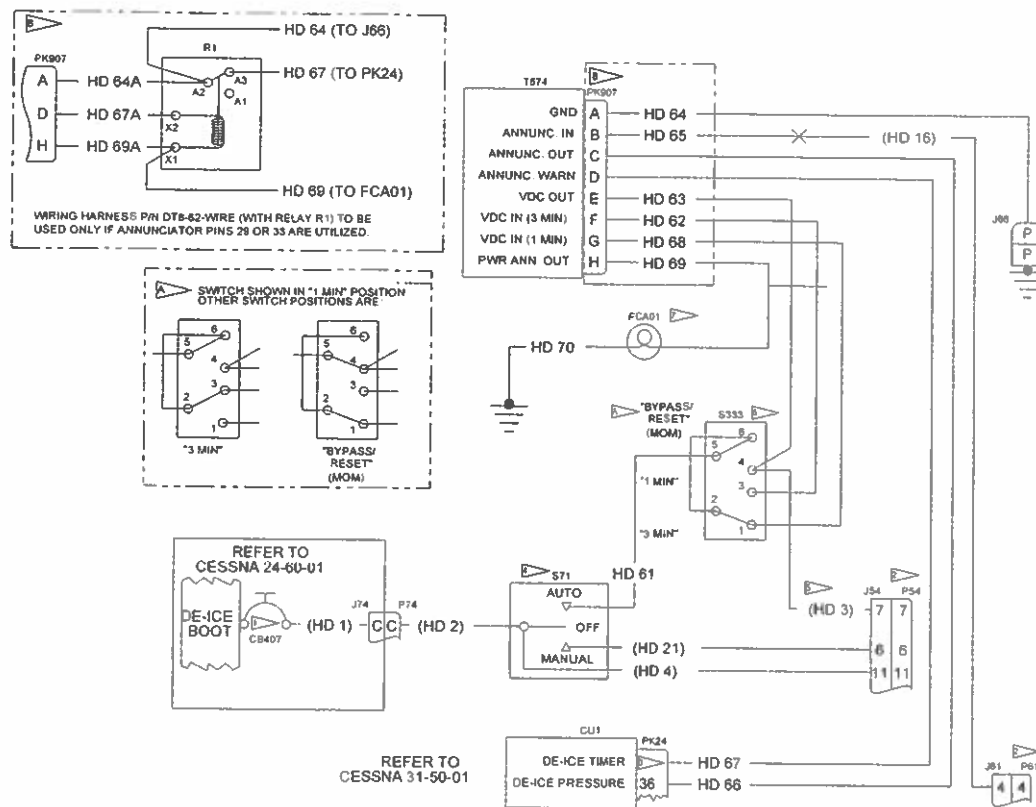

Notes:

1. CB407 is a 5 amp C/B for aircraft without a cargo pod, and a 7.5 amp C/B for aircraft with a cargo pod. See Cessna Wiring Diagram 30-10-01.
2. System is unchanged by the modification beyond existing connectors P54 and P61. See Cessna wiring diagram 30-10-01 for continuation of wiring.
3. Pin used for warning annunciator is dependent on other aircraft equipment. Available pins, in order of preference are pins 18, 47, 29, and 33. Ensure that lens in appropriate annunciator is amber.
4. Cessna switch S71 is replaced with new switch, oriented so switch is momentary when pushed down into MANUAL position.
5. Original Cessna wires unchanged by the modification are shown in parenthesis. Other wires are either new or replace previously existing wires.
6. Switch S333 is installed immediately below switch S71, oriented so switch is momentary when pushed up into BYPASS/RESET position.
7. Indicator FCA01 is installed immediately to the left of switch S333.
8. Optional relay, used only when annunciator pins 29 or 33 are utilized.

Deice Cycler System Wire Table			
Wire	Gauge	Terminal 1	Terminal 2
HD 70	20	18RAD-18277	RA18-6
HD 69A**	20	Solder (PK907)	Solder (M39016/6-207)
HD 69	20	Solder (PK907 or M39016/6-207)	18RAD-18277
HD 68	20	Solder (PK907)	RA18-6
HD 67A**	20	Solder (PK907)	Solder (M39016/6-207)
HD 67	20	Solder (PK907 or M39016/6-207)	S-2341-1
HD 66	20	Solder (PK907)	S-2341-1
HD 65	20	Solder (PK907)	2RA18 (HD 16)
HD 64A**	20	Solder (PK907)	Solder (M39016/6-207)
HD 64	20	Solder (PK907 or M39016/6-207)	S-2099-4
HD 63	20	RA18-6	Solder (PK907)
HD 62	20	RA18-6	Solder (PK907)
HD 61	20	RA18-6 (ALT S-1367-1-6)	RA18-6
HD 21*	20	S-1367-1-6	S-2099-12
HD 16*	20	2RA18 (HD 65)	S-2099-12
HD 4*	20	S-1367-1-6	S-2099-12
HD 3*	20	S-1367-1-6	S2099-12
HD 2*	20	S-2353-5	S-1367-1-6
HD 1*	20	S-1367-1-8	S-2099-12

Deice Cycler System Wiring Diagram Parts		
Item No.	Part Number	Description
T574	ATI-ICE-CYC	Cycler
S71	MS35058-31	Switch
S333	MS27407-5	Switch
R1**	M39016/6-207	Relay
PK907	MS3116F12-8P	Connector
PK24*	S2340F50	Connector
P74*	200513-2	Connector
P61*	S2650-4	Connector
P54*	S235-3	Connector
J74*	S2096-1	Connector
J66*	S2526-1	Connector
J61*	S2349-3	Connector
J54*	S2349-1	Connector
FCA01	45RNG18-2112T3	Indicator Lamp
CU1*	2670104-2	Annunciator Panel
CB407*	Note 1	Circuit Breaker

Deice Cycler System Hardware (Not Shown)		
Qty.	Part Number	Description
4	AN525-10R8	Screw
4	MS21044N3	Nut
4	NAS1149F0332P	Washer
1	DT8-65-WIRE	Wiring Harness (Used for Annunciator Pin 18 or 47)
1	DT8-62-WIRE	Wiring Harness (Used for Annunciator Pin 29 or 33)
1	DT8-WARN	Deice Cycler Inop Annunciator
1	DT8-PLAC	Boot Cycle Selector Switch Placard
2	MS35206-214**	Screw
2	MS21044N04**	Nut

*Existing Prior to Modification

**Optional – Used only with DT8-62-WIRE wiring harness