

INSTRUCTIONS FOR CONTINUED AIRWORTHINESS

**Aero Twin, Inc. Single Place Folding Seat P/N DFS5
for
Cessna Models 208 and 208B Aircraft**

Document No. DFS5-ICA

**Maintenance Manual
Airworthiness Limitations
Illustrated Parts List**

LOG OF REVISIONS			
REVISIONS		PAGES REVISED AND DESCRIPTION OF REVISIONS	APPROVAL SIGNATURE
NO.	DATE		
N/C	04-25-06	Original Issue	JK
A	07-03-12	Revised Pages 2, 6, 7, 11-15, 17, and 18 per ECO AT-147	Jason Kepler
B	05-07-18	Revised All Pages per ECO AT-174	

Information in this publication is based on data available at the time of publication and may be updated, supplemented, and automatically amended by a revision or re-issuance. All such amendments become part of and are specifically incorporated within this publication. Users are urged to keep abreast of the latest amendments to this publication through information available on Aero Twin, Inc.'s website, <http://www.aerotwin.com>. The latest revision of the Instructions for Continued Airworthiness for all of Aero Twin, Inc.'s products are available for download at that website.

<h2 style="margin: 0;">Table of Contents</h2>

Section	Page
Log of Revisions.....	2
Table of Contents	3
1.0 Maintenance Manual	4
1.1 Description.....	4
1.2 Installation/Removal.....	5
1.3 Storage.....	7
1.4 Weight and Balance	7
1.5 Maintenance Instructions.....	9
2.0 Airworthiness Limitations.....	13
3.0 Illustrated Parts List	15
3.1 Complete Parts List	15
3.2 Folding Seat Overview & Back Rest Cover Installation	17
3.3 Seat Bottom Hardware & Lower Arm Installation	18
3.4 Seat Belt and Back Installation	19
3.5 Seat Pan Installation	20
3.6 Seat Track Installation	21
3.7 Shoulder Harness Bracket Installation	22

1.0**Maintenance Manual****Aero Twin, Inc. Single Place Folding Seat, P/N DFS5****1.1 Description**

The Aero Twin single place folding seat is made for installation on the Cessna 208 and Cessna 208B aft cabin shelf in load zone 6, and is designed for quick and simple installation and removal, and compact stowage when not in use. Brownline style utility track has been installed on the aft cabin shelf floor. This new track is capable of receiving the above-mentioned Aero Twin folding seats.

The basic structure of the seat is a welded 4130 steel tube frame. The seat back and legs fold for storage. Two diagonal arms, each hinged at one end and equipped with a quick-release fitting at the other, provide primary structural support for the installed seat. The seat pan is rubber-impregnated high-strength fabric attached to the seat frame with aluminum inserts using sheet-metal screws. The seat back cover is of the same material; it slides over the seat back frame and is secured with nylon straps. Occupant restraint is provided by lap belts attached to the seat frames and diagonal shoulder harnesses, attached to the airframe. The seat is equipped with four identical anti-rattle type track fittings that engage the seat tracks. A one-piece padded upholstery cover is supplied with each seat; this slides over the seat frame and is secured with hook-and-loop strips. The seat is identified by a data plate permanently attached to the back rest lower cross-member. The data plate lists the part number, serial number, and date of manufacture of the seat.

The load zone 6 utility track installation consists of the installation of underfloor doublers and nutplates. Structural screws are used to attach the track to the under-floor structure.

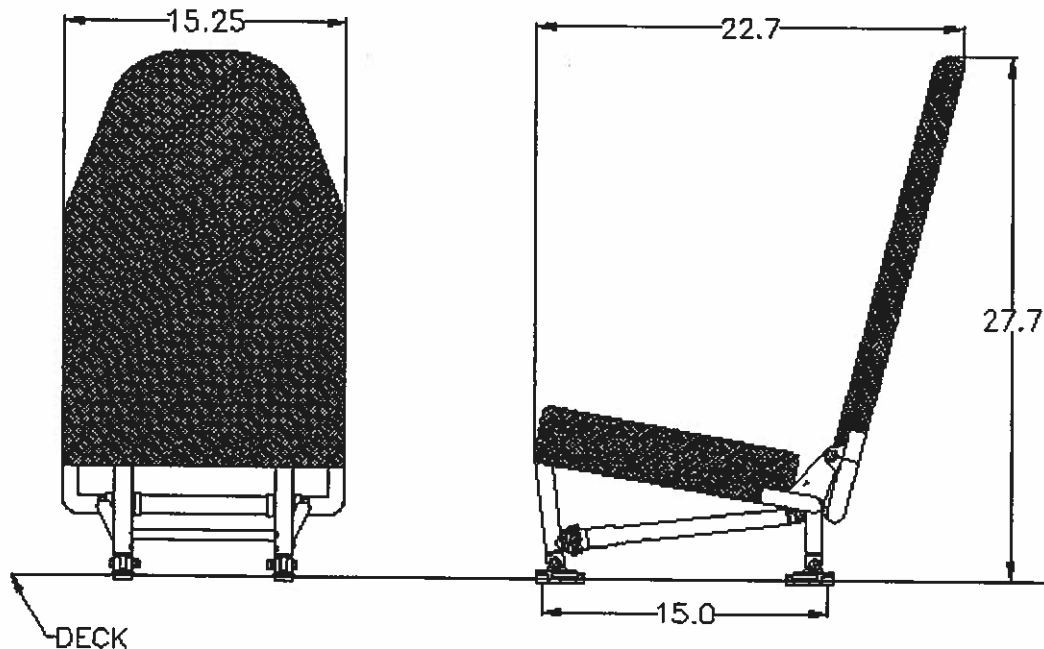

Figure 1.1.1 Basic Seat Dimensions

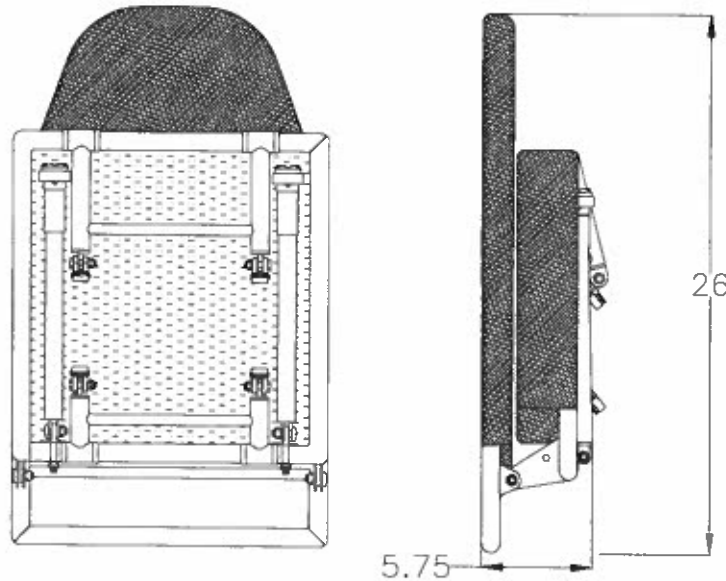

Figure 1.1.2 Folded Seat Dimensions

1.2 Installation / Removal

NOTE: This seat is approved for forward-facing installation only.

1.2.1 Setup and Installation:

1. Unfold forward leg and lower diagonal arms. On each quick-release fitting (item -11), push in the retaining pin and retract the locking ring (see detail in Figure 1.2.1). Position the diagonal arms to align fittings with studs on forward leg. Push forward leg back to engage studs in fittings, then extend locking rings to close jaws.

Be sure jaws close completely and retaining pins pop out to the extended (locked) position - Failure to properly engage studs and lock fittings could result in seat collapse.

2. Unfold rear leg and position the seat over the seat tracks at the desired fuselage station. Drop the forward feet into the tracks (locking lugs must be in the retracted position), slide forward or aft 1/2 inch, and push the locking lugs down to lock the forward feet into the track. Forward lugs must be engaged in the forward most seat track position.
3. Extend the rear legs back to the built-in rotation stop, then move legs forward until aft feet can drop into the tracks. Slide feet aft 1/2 inch and push locking lugs down to lock feet in track. Locking lugs of rear feet should be 15 inches (15 track positions) aft of forward feet locking lugs.
4. The feet are equipped with anti-rattle devices. Use is optional. To use the anti-rattle feature, tighten the screw in the anti-rattle device until the stirrup is drawn snug against the seat track.
5. Fold seat back to full upright position.
6. Clip shoulder harness to the ring fitting on the aft bulkhead, ensuring that the clip fully engages.
7. Update aircraft empty weight and balance to account for seat installation (see Section 1.4).

1.2.2 Removal / Breakdown:

1. Unclip shoulder harness from the ring fitting on the aft bulkhead.
2. Release anti-rattle feature on each of four feet (if feature is utilized).
3. Lift the rear feet locking lugs (a tool designed for this purpose is available from Aero Twin, Inc.). Slide the feet forward 1/2 inch and lift the feet from the track.
4. Repeat step 3 for the forward feet. Remove seat from tracks.
5. Push in the retaining pins and retract the locking rings of the lower diagonal arm quick-release fittings. Disengage the forward leg studs from the fittings.
6. Fold the rear legs up, then the forward legs. Fold the arms into position alongside the forward legs.
7. Fold the seat back down.

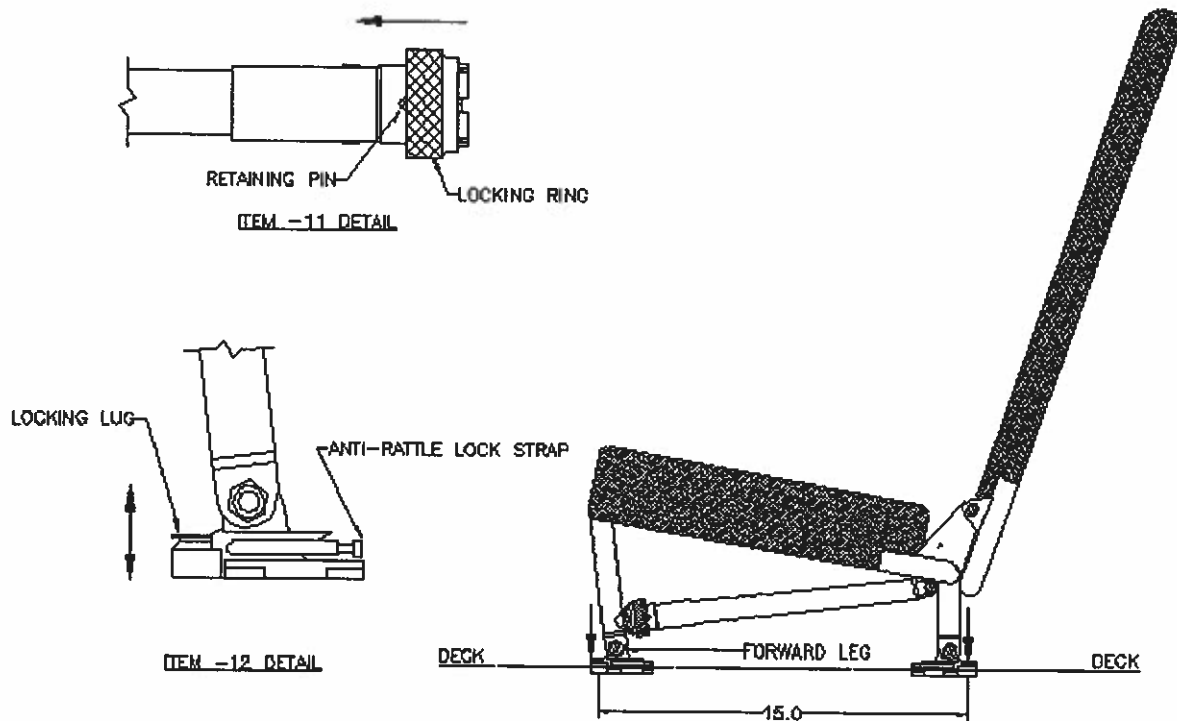
**Figure 1.2.1 Seat Installation**

1.3 Storage

A protective storage bag is available for these seats. For long-term storage it is recommended that the seat be placed in its protective bag. During storage the seats should be kept in a dry location away from any direct heat source.

The seats can be stacked up to six-deep in storage. Do not stack more than 100 lb. on top of a folded seat. Prior to installing a seat which has been in storage for an extended period, inspect and lubricate the seat in accordance with a 1000 hr/Annual inspection, as listed in section 2.1 of this document.

1.4 Weight and Balance

When any seats are installed or removed, the aircraft empty weight and balance must be updated to reflect the configuration change. This section includes information required for weight and balance calculations pertaining to the installation of Aero Twin seats. The under-floor structure and brown-line additions should be included in the aircraft basic empty weight at the time of initial installation. (See installation instructions document DFS5-IM)

1.4.1 Calculation of Effect on Aircraft Empty Weight and Balance:

When installing Aero Twin single place folding seats in any configuration, the effect on aircraft empty weight and moment must be determined for that configuration. The center of gravity of the unoccupied seat is 11.7 inches aft of the forward feet locking lugs. See Figure 1.4.2.

Individual seat weight of the DFS5 seat is 18 pounds.

Weight, arm, and moment for a single installed seat, unoccupied:

	Cessna 208		Cessna 208B	
Wt.	Arm	Moment/1000	Arm	Moment/1000
18 lbs	296.2	5.3	344.2	6.2

Weights and moments of installed seats are added to the weight and moment of the empty airplane (without the DFS5 passenger seats); dividing total moment by total weight yields the C.G. of the empty airplane *with* DFS5 passenger seats.

PASSENGER LOADING, WEIGHT AND BALANCE:

Seat occupant centers of gravity are located 8.8 inches aft of the locking lug on the forward feet. See Figure 1.4.1.

Weight, arm, and moment for a single occupant in a DFS5 seat:

	Cessna 208		Cessna 208B	
Passenger Wt.	Arm	Moment/1000	Arm	Moment/1000
(170)*	293.3	(49.9)*	341.3	(58.0)*

* Numbers in parenthesis are for a typical 170 lb passenger; use actual passenger weights.

Because the DFS5 seats are at the aft extreme of the cabin, they should be reserved for the lightest occupants in the aircraft. Extra care should be taken when calculating the aircraft center of gravity when these seats are occupied, to ensure that the aft center of gravity limit is not exceeded.

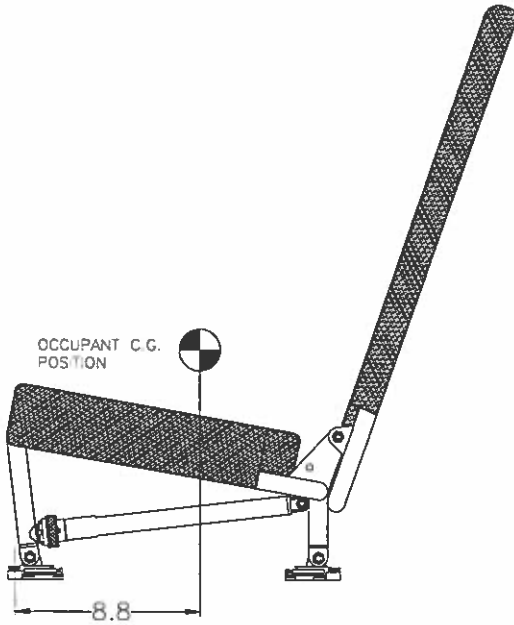

Figure 1.4.1 Occupant C.G.

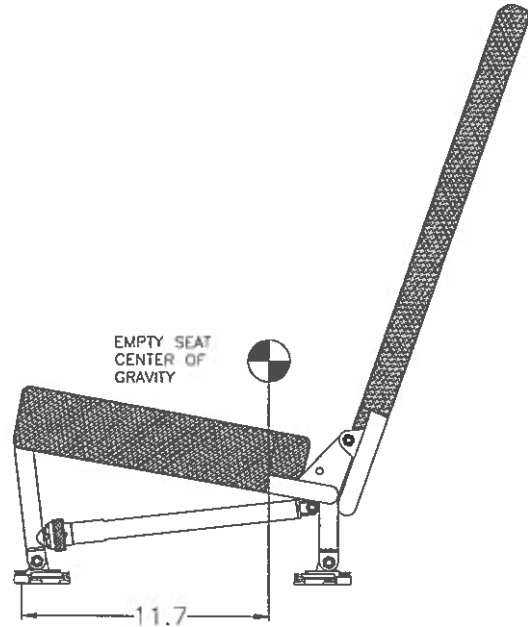

Figure 1.4.2 Empty Seat C.G.

1.5 Maintenance Instructions

1.5.1 General:

The Aero Twin Single Place Folding Seat and Utility Track installation is designed to be highly durable and fairly maintenance free. However, a maintenance program has been established, in accordance with Appendix G of 14 CFR Part 23, to assure the continued airworthiness of the seats and track installation. Adherence to the established plan is mandatory and records of performance of required inspections and maintenance must be maintained. See Section 2.0, Airworthiness Limitations, for required maintenance items and intervals.

1.5.2 Cleaning:

1.5.2.1 Upholstery:

- For general dust and light dry soiling, vacuum upholstery thoroughly, and or brush with a clean stiff bristle brush. Avoid beating fabric as this can hasten wear and does not effectively clean the upholstery. Use of commercially available upholstery shampoo will remove most soil encountered in normal service. Follow product directions.
- For oil or grease stains, solvent-type cleaning agents can be effective. Test a small inconspicuous area of the fabric first. Use solvent-type agents sparingly, without saturating fabric. Apply with a clean soft cloth and work from the edge of the stain towards the center to avoid spreading. Observe appropriate safety precautions when using any solvent agent.
- For heavy, saturating stains (coffee, vomit, etc.) the upholstery cover should be removed and commercially dry-cleaned.

1.5.2.2 Seat Track:

The track should be kept clean, as dirt and contaminants can wear on the track and cause difficulty in installing and removing hardware. Cleaning may be done in a variety of ways as long as chemicals or tools used do not corrode or wear down the track.

1.5.2.3 Herculite fabric (seat pan and seat back cover):

Clean the Herculite fabric components using mild soap and water solution or a commercial vinyl cleaner. For heavy grease or oil stains, a diluted solution of Simple Green or equivalent cleaning solution can be used. Avoid excessive wetting of the fabric when installed on the seat, as moisture can collect between the fabric and tube structure and promote corrosion.

1.5.2.4 Metal Parts:

Moisten a clean soft cloth with a solvent-type cleaner or undiluted Simple Green or equivalent; thoroughly wipe metal parts completely clean. Wipe dry with a clean dry cloth. After heavy cleaning over or near lubricated joints, relubricate as appropriate.

1.5.3 Lubrication and Corrosion Prevention:

The hinged leg connections to the seat frame must be kept well lubricated and protected from moisture. *Corrosion X™* is a product that is well suited to this dual purpose. This product is available from Aero Twin, Inc., or your local aviation supplier. Other commercial products are available that will perform well. WD-40 is not recommended, as its moisture displacement properties are inadequate.

The required maintenance procedures for the seat include lubrication and internal treatment of the steel tubes at specific intervals. The seat should also be lubricated if it is subjected to heavy moisture for any reason, or after thorough cleaning of the metal frame.

- To lubricate the rotating and sliding joints, spray lubricant into the joint while rotating or sliding the fitting (avoid over spray on the upholstery cover by first pulling the cover back from the joint). Wipe off all excess lubricant with a clean dry cloth.
- To internally treat the steel tubes, the upholstery cover and Herculite fabric seat pan and seat back cover should be removed. Using a small nozzle, spray *Corrosion X™* (or equivalent) into all available holes. Allow the frame to sit for several minutes to allow excess to drain as it may, then wipe off all external surfaces with a clean, dry cloth. Reassemble seat.
- If the painted surface of the steel tube structure is marred in service or during handling, the affected area should be repainted to prevent corrosion. See instructions in section 1.5.5.3.

1.5.4 Disassembly / Assembly:

1.5.4.1 Disassembly:

- To remove the padded upholstery backrest cover, pull the flap free from the hook-and-loop strips on the lower part of the back rest, then slide the cover up and off the back.
- To remove the seat cushion and upholstery: disconnect the 3 flaps from the hook and loop strips on the sides and front of the seat pan. Pull the cushion and upholstery forward off the pan.
- To remove the Herculite seat back cover, loosen and release the strap buckles on the aft side of the seat, then slide the cover off of the seat back frame.
- To remove the Herculite seat pan, remove the sheet metal screws from the underside of the seat frame.
- Disassembly of the seat frame is straightforward, as all connections utilize standard aircraft hardware.
- The utility seat track must be removed from the aircraft floor to gain access to the access panels in the floor. To remove the track, remove the three (3) screws attaching each seat track to the floor. The tracks must be reinstalled using MS24694S51 screws before reinstalling the seats. Replace any worn screws with appropriate hardware.
- The under-floor portions of the utility track installation, doublers and nutplates, are considered permanent.

1.5.4.2 Assembly:

Refer to the Illustrated Parts List when reassembling the seat frame.

Replace self-locking type nuts with new hardware when reassembling seat.

Any time the Herculite seat pan is removed, use new screws for reinstallation.

Use standard torques except as follows:

- The nuts on the seat back hinge bolts, which retain the lap belts, should be snug but not over-tight to allow rotation of the seat back and the lap belt fittings.
- The nuts on the clevis bolts at the upper ends of the two arm assemblies, and the nuts that retain the two eyebolts to which the arms attach, should be snug but not over-tight to allow rotation of the arms for folding.
- The nuts and bolts which attach the feet (seat track fittings) to the eyebolts at four locations should not be tightened so much as to cause distortion of the cast lugs on the fitting.
- The seat belt and shoulder harness system is the same for both the left and right seats, except that the orientation is mirrored. For a seat installed on the left hand side of the aircraft, the seat belt and shoulder harness system must be installed with the push button buckle on the right hand side of the seat and the shoulder harness running from the right hand hip of the occupant to the left hand shoulder. The seat belt and shoulder harness must be reversed for a seat installed on the right hand side of the aircraft.

1.5.4.3 Adjustments:

- Arm Assemblies: These members are not adjustable.

1.5.5 Seat Repair:

1.5.5.1 Hardware Replacement:

Hardware and fittings used throughout the seat are aircraft standard. Hardware should be replaced if corroded, damaged, or excessively worn. Replace self-locking type nuts with new hardware when reassembling seat. Do not substitute hardware - refer to the Illustrated Parts List for correct part numbers. If you encounter difficulty procuring replacement hardware or fittings, contact Aero Twin, Inc. at (907) 274-6166. Refer to previous section for assembly information.

1.5.5.2 Steel Tube Frame:

Before any repairs may be made to the steel tube frame, written approval must be obtained from the manufacturer, Aero Twin Inc. Contact Aero Twin Engineering Department at (907) 274-6166 or write: Aero Twin Inc., Engineering Dept., 2403 Merrill Field Dr., Anchorage AK, 99501.

NOTE: Arm Assemblies (P/N FS1-500), are not eligible for repair. If these parts are found to be bent or cracked, they must be discarded and replaced.

1.5.5.3 Painted Surfaces:

Painted steel surfaces should be maintained and refinished as required to prevent corrosion. When refinishing is required, lightly sand the affected area using fine sandpaper or an abrasive pad (such as 3M *Scotch-Brite*™). Polish out minor surface nicks or scratches where present. Clean the area thoroughly with a clean cloth wetted with non-petroleum-based solvent to remove any residual oils and dust. Apply a zinc-chromate or equivalent

primer coat, then a matching color coat of quality enamel or epoxy-type paint. Follow manufacturer's instructions in preparing and applying primer and color coats.

1.5.5.4 Fabric:

- **Herculite Components:** These components are subject to mandatory replacement at fifteen-year intervals, but should be replaced when found to be excessively worn, frayed, or torn. Open seams can be re-stitched using nylon thread.
- **When replacing the Herculite seat pan with a new assembly:**
 - Ensure that metal strips in edge are positioned in their pocket with the outside edge against the fold of the pocket.
 - Position the seat pan on the metal frame with the existing screw holes centered in both the metal strips and the nylon webbing.
 - Match drill the seat pan to the existing screw holes using a #32 drill bit and secure the pan to the frame using S1021A6-8 or MS51863-23C screws.
- **Upholstery:** Re-stitch open seams using nylon thread. Small tears can be drawn closed and sewn. Extensive damage usually justifies replacement of the upholstery cover.
- **Foam:** The seat is not approved for operation without the foam supplied with the seat, or equivalent. Padding should only be replaced with medium density highly damped, semi-reticulated urethane foam. Confor Foam CF-45 (bottom layer), CF-40 (middle two layers), and DAX-55 scrim (top layer) are acceptable replacements.

1.5.5.5 Restraint Belts:

The belt assemblies are subject to mandatory replacement at twelve-year intervals. Worn, frayed, cut, or otherwise damaged belt assemblies should be replaced or remanufactured immediately by a qualified repair station. Any belt assembly that is found to be missing its manufacturer's data patch must be considered unairworthy and must be replaced.

1.5.5.6 Seat Feet:

The seat track fittings that serve as seat feet use a plunger that slides up and down on a steel body and locks into the seat track when pushed down. A retaining pin is in the front of the body that is pushed out by a small spring to sit in a groove inside the plunger. The pin keeps the plunger from falling off the bottom of the body. Sometimes the plunger can be jarred out of place and the pin, spring, and ball that the spring seats on are lost. A repair kit, ATI-40566-R, is available, which provides replacement pins, springs, and balls. Later seat feet incorporate a roll pin to further restrict the plunger from falling off the bottom of the body.

1.5.6 Floor Structure Repairs:

Repairs to the utility track are not authorized, contact Aero Twin Inc. for replacement parts.

2.0**Airworthiness Limitations****Aero Twin, Inc. Single Place Folding Seat P/N DFS5**

The Airworthiness Limitations section is FAA approved and specifies maintenance required under paragraphs 43.16 and 91.403(c) of the Federal Aviation Regulations unless an alternative program has been FAA approved.

This section describes required inspection, maintenance, and replacement items. When repairs are deemed necessary, follow accepted standard practices and/or specific maintenance instructions in Section 1.5 of this manual. This section constitutes Component Airworthiness Limitations which apply to the seat and utility track installation only.

2.1 Scheduled Inspections and Maintenance:

Note: First inspection should be accomplished at next aircraft inspection so that subsequent inspections coincide.

2.1.1 First 100-hour and subsequent 1000 hour or Annual Inspection:

Visually inspect the tracks for secureness. The track will be inspected for damage that would compromise its ability to fasten and secure. An example of unacceptable damage would be bent, broken, cracked or extremely worn securing tabs. The seat track should be free from debris.

2.1.2 1000 hour or Annual Inspection:

Remove padded upholstery cover.

Inspect steel tube frame:

Tubes for bends, dents, corrosion, or other defects.

Welded areas for cracks or other defects.

Finish for scratches, abrasion, etc.

Inspect hardware and fittings:

Hardware for security and condition.

Quick-release fittings for proper operation and condition.

Feet (track fittings) for proper operation, security, and condition.

Inspect Herculite fabric (seat pan and seat back cover):

Fabric for wear, fraying, tearing, or other defects

Attachment screws (seat pan) for security

Straps and buckles (seat back) for condition and tautness

Inspect restraint system (lap belts and shoulder harness assemblies):

Webbing for cuts, fraying, or other defects.

End fittings for security and condition.

Airframe shoulder harness ring fittings for security and condition.

Buckles for proper operation.

Data patches (must be present and legible).

Inspect overall seat assembly and upholstery for cleanliness and general airworthiness.

Lubricate all rotating and sliding parts fittings (Corrosion X™ or equivalent).

Reinstall padded upholstery cover.

FAA Approved: _____

Date: _____

2.1.3 Five-Year and Ten-Year Inspection:

- Remove padded upholstery cover.
- Remove Herculite seat pan and seat back cover.
- Inspect steel tube frame:
 - All welded joints using a 10X glass for cracks.
 - (Strip paint from area around any apparent crack and re-inspect).
- Treat all tubing internally with corrosion preventative (*Corrosion X™* or equivalent).
- Complete all items for a **1000 Hour / Annual Inspection**.
- Reinstall seat pan using new screws; reinstall seat back cover and upholstery cover.

2.1.4 Fifteen-Year Inspection:

- Remove padded upholstery cover.
- Remove Herculite seat pan and seat back cover and discard.
- Disassemble seat frame.
- Strip paint from all welded joints and inspect using a 10X glass.
- Complete all items for a **5/10-Year Inspection**.
- Repaint seat frame components.
- Reassemble seat frame using new hardware.*
- Install NEW Herculite seat pan and seat back cover.*
- Reinstall padded upholstery cover.

*A kit containing all parts necessary to complete these steps is available from Aero Twin, Inc. Call (907) 274-6166, or visit www.aerotwin.com to order Kit No. DFS5-H.

2.1.5 Restraint Belt Restrictions:

In addition to the above inspection schedule, the restraint belt assembly must be replaced every 12 years per the restraint belt manufacturer's limitations.

2.2 Mandatory Replacement:

Herculite seat pan and seat back cover, P/N FS1-600 and FS1-700-1 respectively, must be replaced by new parts during 15 year inspection as discussed in 2.1.4.

Restraint belt assembly, P/N 5-02-6M5701RevA, must be replaced every 12 years as discussed in 2.1.5.

FAA Approved: _____

Date: _____

-----End of Section 2.0 Airworthiness Limitations-----

3.0 Illustrated Parts List

Aero Twin, Inc. Single Place Folding Seat P/N DFS5

3.1 Complete Parts List:

The following is a complete parts list for the DFS5 seat and the installation components including the seat tracks, floor doublers, and shoulder strap brackets and their associated hardware. The installation instruction for those items is detailed in document DFS-IM and drawings DFS5-I and DFS5-SS-I, all of which were supplied with the aft seats kit package. The shoulder strap brackets, floor doublers, and seat tracks are considered permanently installed parts for the aircraft.

Item	Qty (per seat)	Part Number	Description	Appears on Fig:
DFS5 Seat:				
1	1	FS1-100	Seat Pan Frame	3.2, 3.3, 3.4, 3.5
2	1	FS1-400-1	Seat Back Frame	3.2, 3.4
3	2	FS1-500	Arm Assembly	3.2, 3.3
4	1	FS1-600	Seat Pan Assembly	3.5
5	1	FS1-700-1	Back Rest Assembly	3.2
6	2	MS21083N4	Nut	3.4
7	2	NAS75-4-007	Steel Bushing	3.4
8	12	MS51863-23C or S1021A6-8	Seat Pan Screw	3.5
9	4	ATI-SFT-14 or -15	Retainer	3.3
10	10	MS21083N5	Lock Nut	3.3, 3.4
11	2	ATFS-62L	Eye Bolt	3.3
12	4	AN5-11A	Bolt	3.3
13	4	AN25-14A or AN5-10A	Clevis Bolt	3.3, 3.4
14	2	AN24-12A or AN4-7A	Clevis Bolt	3.4
15	2	ATFS-115A	Steel Bushing	3.4
16	A/R	NAS1149F 0532P/0563P	Washer	3.3, 3.4
17	A/R	NAS1149F 0432P	Washer	3.4
18	1	5-02-6M5701RevA	Seat Belt Assembly	3.4
19	1	FS1-605-1	Seat Cushion	3.2
33	1	FS1-605-3	Seat Cushion Upholstery	3.2
34	1	FS1-406	Seat Back Cushion	3.2
35	1	FS1-407	Seat Back Cushion Upholstery	3.2

Figure 3.1

3.1 Complete Parts List (Continued):

Item	Qty (per seat)	Part Number	Description	Appears on Fig:
Floor Modification:				
20	4	DFS5-ST	Seat Tracks	3.6
21	12	MS24694S51	Screws	3.6
22	8 ¹	MS21047L3K	Nutplates	3.6
23	12 ¹	MS21053L3K	Nutplates	3.6
24	24	MS20426AD3-4 ²	Rivets	3.6
25	12 ¹	MS20426AD4-4 ²	Rivets	3.6
Shoulder Harness Attachment Brackets				
26	1	2612093-1 or DFS5-SS-L	LH Shoulder Harness Bracket	3.7
27	1	2612093-2 or DFS5-SS-R	RH Shoulder Harness Bracket	3.7
28	18	MS20470AD4-5 ²	Rivets	3.7
29	38	MS20470AD4-4 ²	Rivets	3.7
30	2	40149-14	Ring Anchor Fitting	3.7
Under Floor Doublers				
31	1	DFS5-FD-R	Right Hand Floor Doubler	(not shown)
32	1	DFS5-FD-L	Left Hand Floor Doubler	3.6
Accessories:				
N/A	N/A	--	Upholstery Cover	(not shown)
N/A	N/A	ATFS1-09	Storage Bag	(not shown)
N/A	N/A	AT-SRT-01	Removal Tool	(not shown)
N/A	N/A	AT-40566-R	Seat Foot Repair Kit	(not shown)

Figure 3.1 (Continued)

¹ Not all nutplates are used in the installation. Items 22 and 23 may be mixed and matched depending on the location of existing rivets. Total number of nutplates used is 12. Quantity of item 25 is also dependent on the location of existing rivets.

² Length of rivets, items 24, 25, 28, and 29 may be adjusted as required by the installer.

3.2 FOLDING SEAT OVERVIEW & BACK REST COVER INSTALLATION

-35	FS1-407	SEAT BACK CUSHION UPHOLSTERY
-34	FS1-406	SEAT BACK CUSHION
-33	FS1-605-3	SEAT CUSHION UPHOLSTERY
-19	FS1-605-1	SEAT CUSHION
-5	FS1-700-1	BACK REST ASSEMBLY
-3	FS1-500	ARM ASSEMBLY
-2	FS1-400-1	SEAT BACK FRAME
-1	FS1-100	SEAT PAN FRAME
ITEM	PART NO.	DESCRIPTION

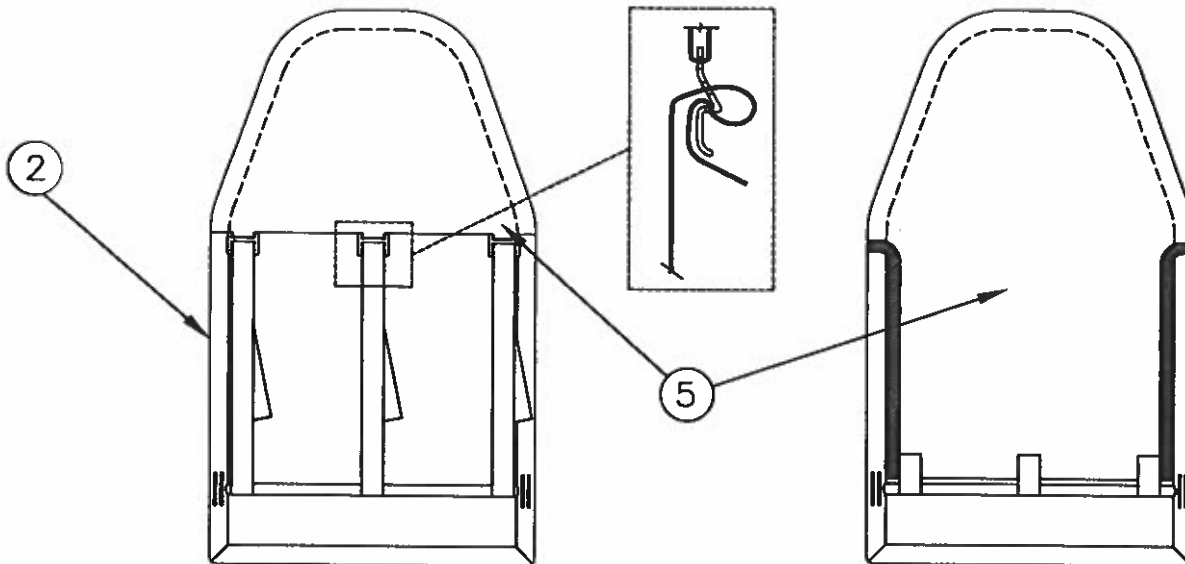
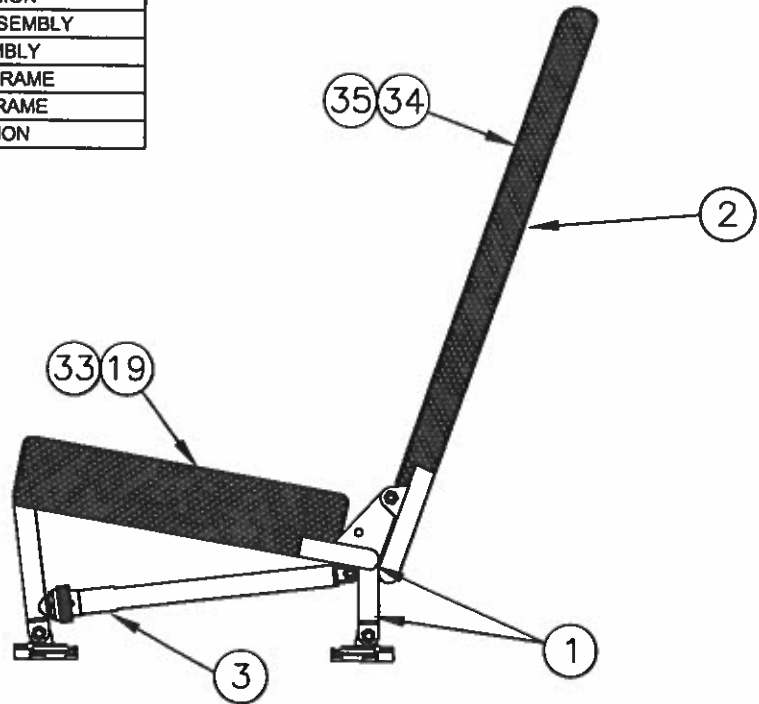

REAR VIEW:
INSTALLED BACK
REST COVER

FRONT VIEW:
INSTALLED BACK
REST COVER

FIGURE 3.2

3.3 SEAT BOTTOM HARDWARE & LOWER ARM INSTALLATION

-16	NAS1149F 0532P/0563P	WASHER
-13	AN25-14A or AN5-10A	CLEVIS BOLT
-12	AN5-11A	BOLT
-11	ATFS-62L	EYE BOLT
-10	MS21083N5	LOCK NUT
-9	ATI-SFT-14 OR -15	RETAINER
-3	FS1-500	ARM ASSEMBLY
-1	FS1-100	SEAT PAN FRAME
ITEM	PART NO.	DESCRIPTION

*IF OPTIONAL P/N ATI-SFT-15 IS USED, ADD ITEM -16 WASHERS SYMMETRICALLY BETWEEN EYE BOLT AND ITEM -9 AS NECESSARY TO REMOVE EXCESSIVE SLOP IN THE RETAINER ATTACHMENT.

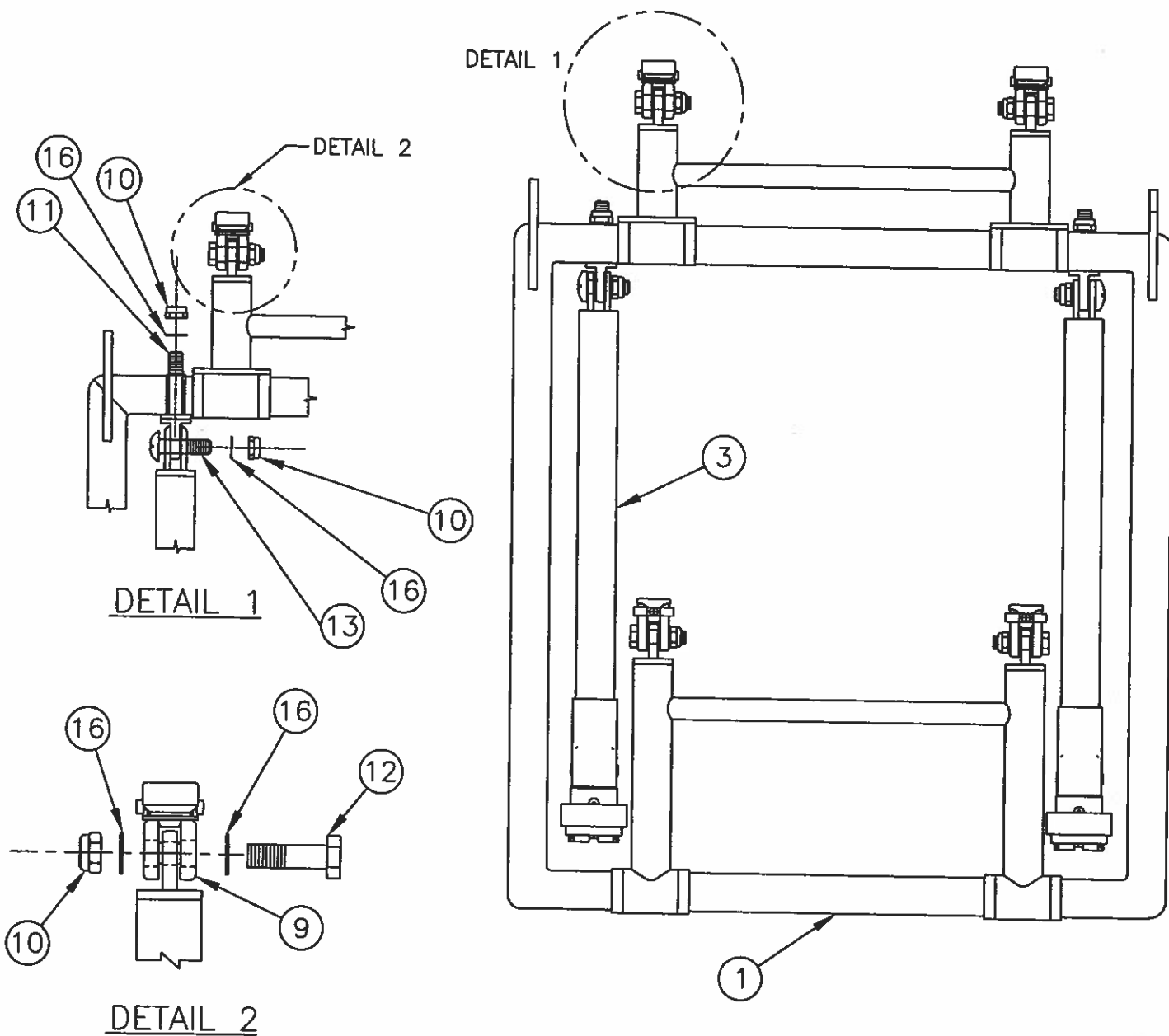

FIGURE 3.3

3.4 SEAT BELT AND BACK INSTALLATION

-14	AN24-12A or AN4-7A	CLEVIS BOLT
-13	AN25-14A or AN5-10A	CLEVIS BOLT
-10	MS21083N5	LOCK NUT
-7	NAS75-4-007	STEEL BUSHING
-6	MS21083N4	NUT
-2	FS1-400-1	SEAT BACK FRAME
-1	FS1-100	SEAT PAN FRAME
ITEM	PART NO.	DESCRIPTION

-18	5-02-6M5701RevA	SEAT BELT ASSEMBLY
-17	NAS1149F 0432P	WASHER
-16	NAS1149F 0532P/0563P	WASHER
-15	ATFS-115A	STEEL BUSHING
ITEM	PART NO.	DESCRIPTION

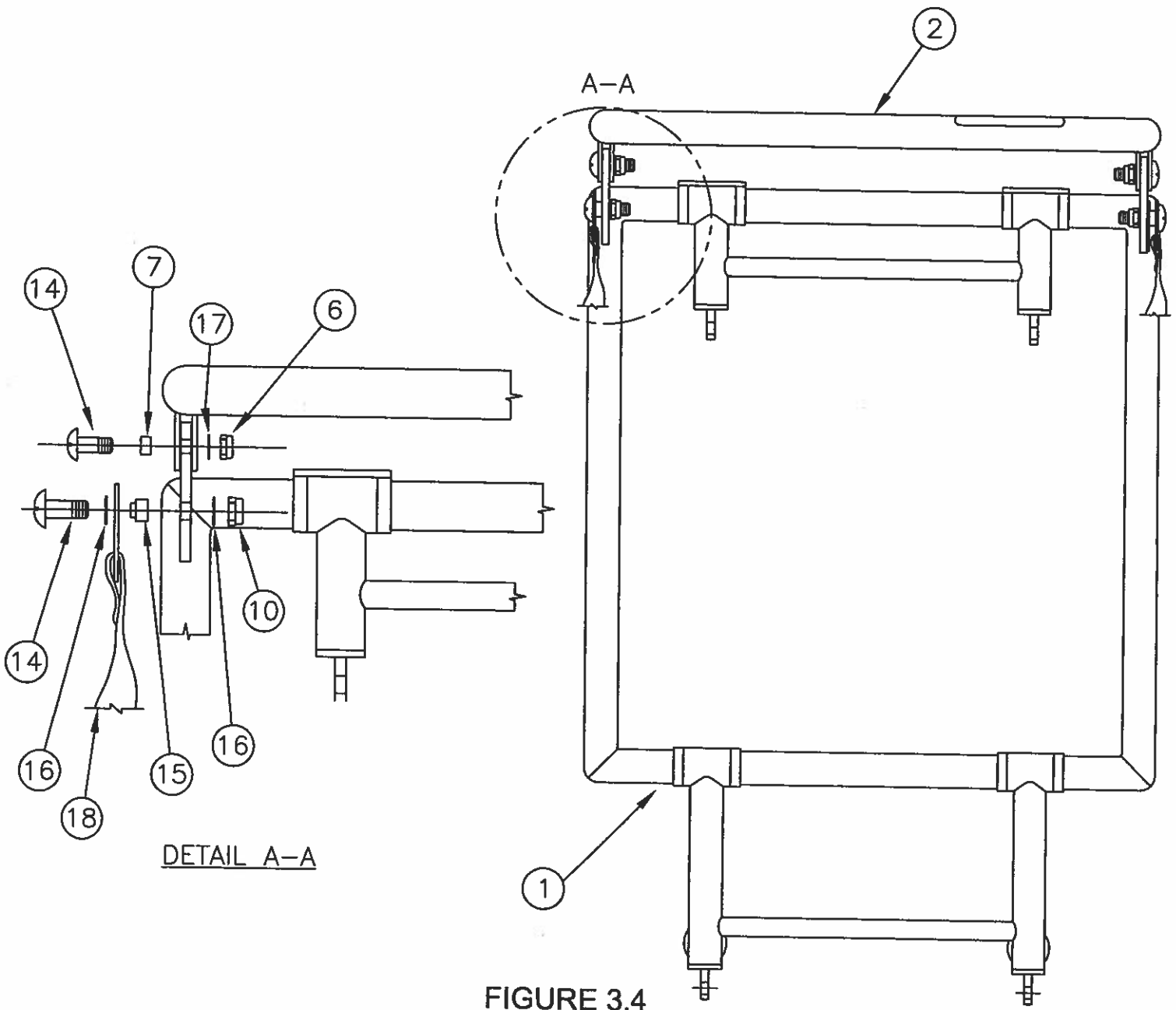
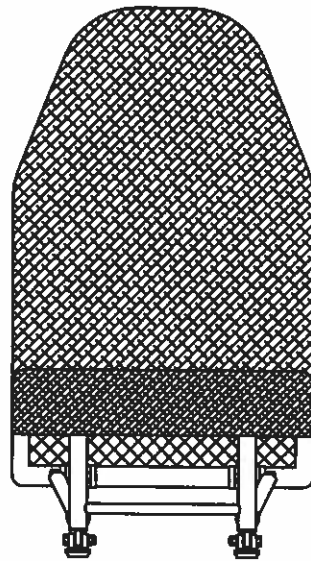

FIGURE 3.4

3.5 SEAT PAN INSTALLATION

-8	MS51863-23C OR S1021A6-8	SEAT PAN SCREW
-4	FS1-600	SEAT PAN ASSEMBLY
-1	FS1-100	SEAT PAN FRAME
ITEM	PART NO.	DESCRIPTION



FRONT VIEW

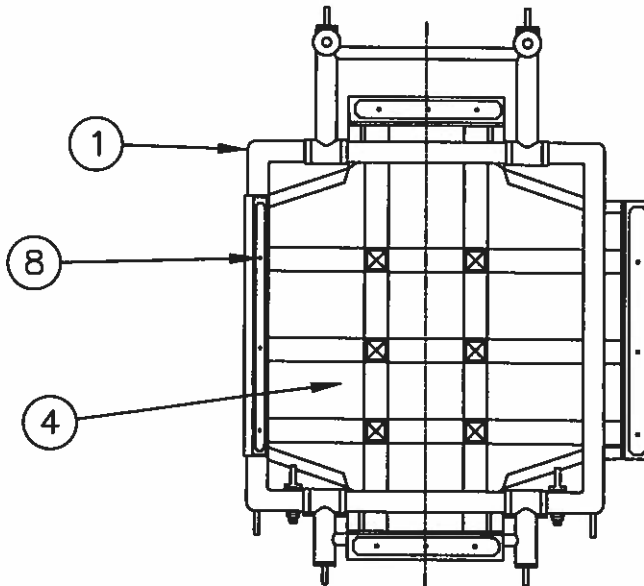

SEAT BOTTOM VIEW

FIGURE 3.5

3.6 SEAT TRACK INSTALLATION

-20	DFS5-ST	SEAT TRACK
-21	MS24694S51	SCREW
-22	MS21047L3K	NUTPLATE
-23	MS21053L3K	NUTPLATE
-24	MS20426AD3-4	RIVET
-25	MS20426AD4-4	RIVET
-29	MS20470AD4-4	RIVET
-31	DFS5-FD-R	RIGHT HAND FLOOR DOUBLER
-32	DFS5-FD-L	LEFT HAND FLOOR DOUBLER
ITEM	PART NO.	DESCRIPTION

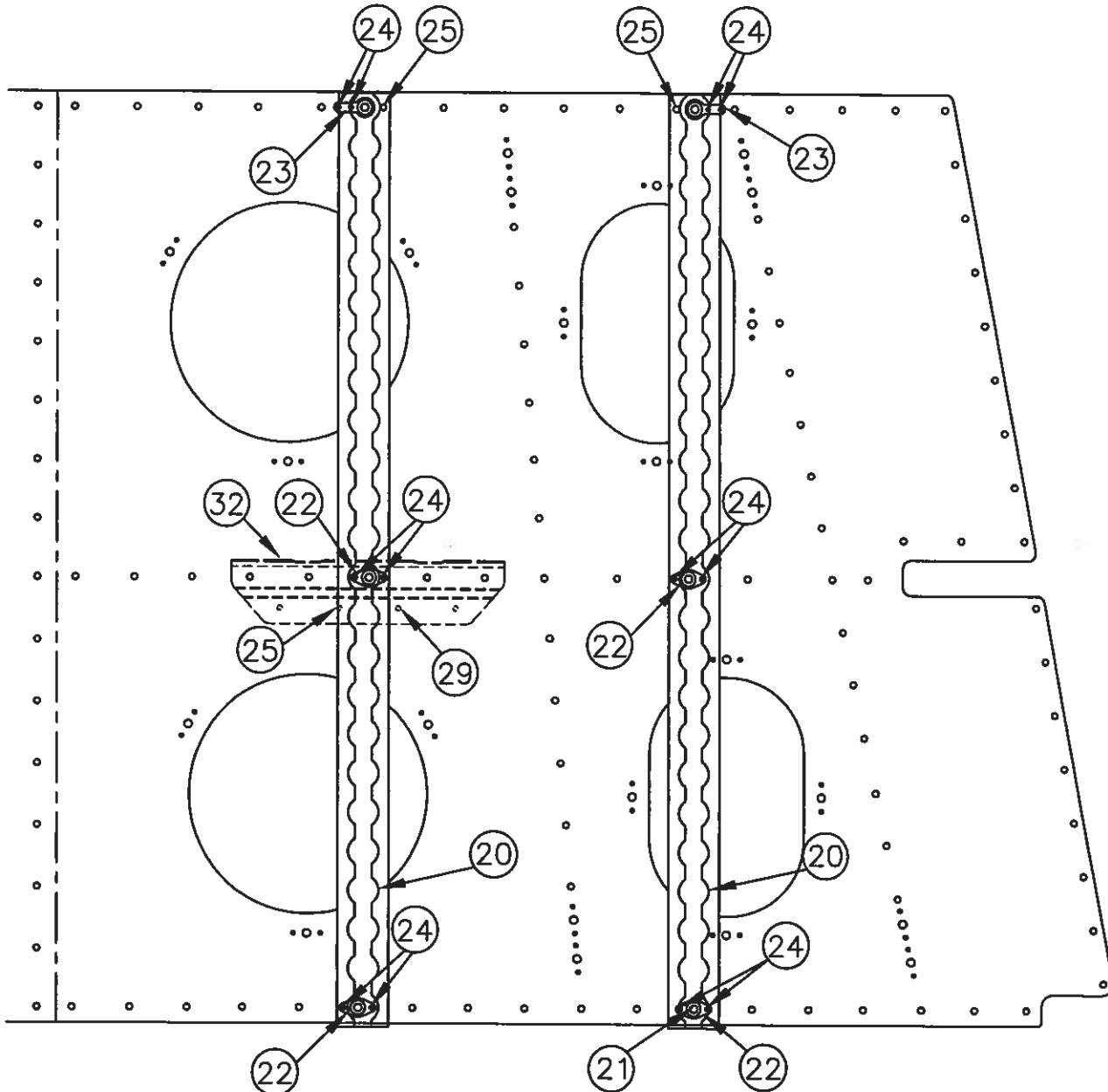

LEFT HAND SIDE SHOWN. RIGHT HAND SIDE IS MIRROR IMAGE. ITEM -31 (NOT SHOWN) INSTALLED ON RIGHT SIDE IN SIMILAR MANNER AS ITEM -32.

FIGURE 3.6

3.7 SHOULDER HARNESS BRACKET INSTALLATION

-26	2612093-1 OR DFS5-SS-L	LH SHOULDER HARNESS BRACKET
-27	2612093-2 OR DFS5-SS-R	RH SHOULDER HARNESS BRACKET
-28	MS20470AD4-5	RIVET
-29	MS20470AD4-4	RIVET
-30	40149-14	RING ANCHOR FITTING
ITEM	PART NO.	DESCRIPTION

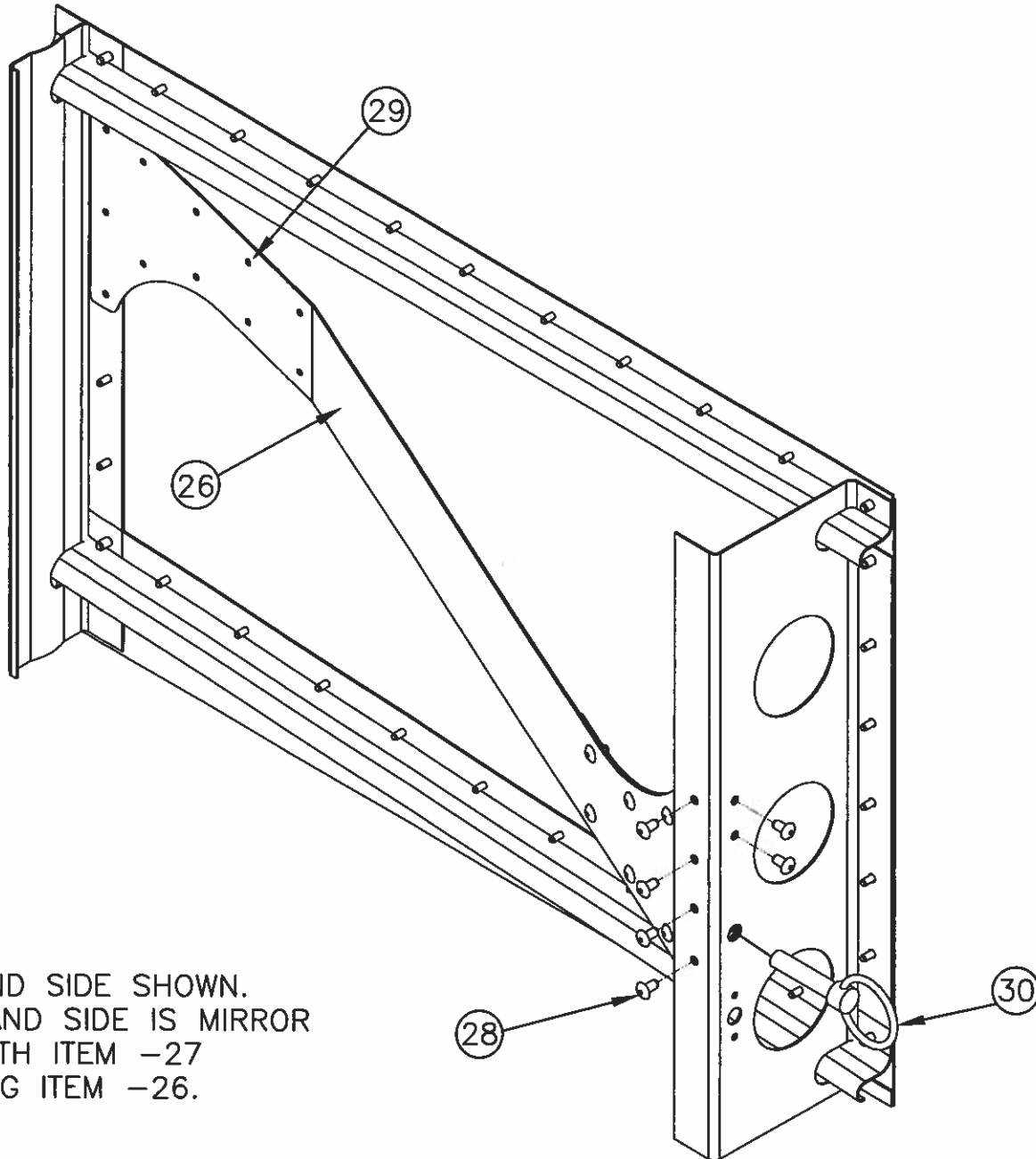

FIGURE 3.7