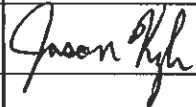

Aero Twin, Inc. Single Place Folding Seat P/N DFS1-01W
for
Pilatus Model PC-12, PC-12/45, PC-12/47, and PC-12/47E Aircraft

**INSTRUCTIONS FOR CONTINUED
AIRWORTHINESS**

Document No. DFS1W-1-ICA1

Maintenance Manual
Airworthiness Limitations
Illustrated Parts List

LOG OF REVISIONS			
REVISIONS		PAGES REVISED AND DESCRIPTION OF REVISIONS	APPROVAL SIGNATURE
NO.	DATE		
--	--	Original Issue	--
A	7/20/05	ECO AT-110, changed pages 2 and 18	
B	2/08/06	ECO AT-111, changed pages 2, 18, and 20	JMK
C	8/04/06	ECO AT-112, pages 1, 2, 10, and 11	JK
D	4/30/08	ECO AT-124, pages 1, 2, 9, 10, 11, and 15	JK
E	7/03/12	ECO AT-147, pages 2, 7, 9, 14-18, and 20	JK
F	9/26/12	ECO AT-149, pages 2, 18, and 20	Jason Kepler
G	12/24/13	ECO AT-160, pages 2, 18, and 21	Jason Kepler
H	4/01/17	ECO AT-170, pages 2, 4, 5, 8-10, 13-15, 18, and 19	Cordell Wright
I	5/07/18	ECO AT-174, pages 2, 15, 18, and 19	

Information in this publication is based on data available at the time of publication and may be updated, supplemented, and automatically amended by a revision or re-issuance. All such amendments become part of and are specifically incorporated within this publication. Users are urged to keep abreast of the latest amendments to this publication through information available on Aero Twin, Inc.'s website, <http://www.aerotwin.com>. The latest revision of the Instructions for Continued Airworthiness for all of Aero Twin, Inc.'s products are available for download at that website.

Table of Contents

Section	Page
Log of Revisions	2
Table of Contents	3
1.0 Maintenance Manual.....	4
1.1 Description.....	4
1.2 Installation/Removal	5
1.3 Storage	9
1.4 Weight and Balance.....	9
1.5 Maintenance Instructions	12
2.0 Airworthiness Limitations	16
3.0 Illustrated Parts List.....	18
3.1 Complete Parts List	18
3.2 Folding Seat Overview & Back Rest Cover Installation	19
3.3 Seat Bottom Hardware & Lower Arm Installation	20
3.4 Seat Belt and Back Installation	21
3.5 Lower Arm Detail.....	22
3.6 Seat Pan Installation.....	23

1.0**Maintenance Manual****Aero Twin, Inc. Single Place Folding Seat, P/N DFS1-01W****1.1 Description**

The Aero Twin single place folding seat for the Pilatus PC-12 is designed for quick and simple installation/removal, and compact stowage when not in use. The seats are designed to work with OEM seat track and produced in a right and left side version.

The basic structure of the seat is a welded 4130 steel tube frame. The seat back and legs fold for storage. Two lower diagonal arms, each hinged at one end and equipped with a quick-release fitting at the other, provide primary structural support for the installed seat. Upper arms equipped with quick release fittings support the seat back. The seat pan is rubber-impregnated high-strength fabric attached to the seat frame with aluminum inserts and steel screws. The seat back cover is of the same material; it slides over the seat back frame and is secured with nylon straps. Occupant restraint is provided by lap and shoulder belts attached to the seat back and pan frames, respectively. The left side seats have the shoulder harness attached on the left hand side of the seat back and the right side versions have them on the right hand side. The seat is equipped with four identical anti-rattle type track fittings that engage the seat tracks. A two-piece padded upholstery cover is supplied with each seat; this slides over the seat pan frame and back and is secured with Velcro® strips. The seat is identified by a data plate permanently attached to the inside of right rear leg. The data plate lists the part number, serial number, and date of manufacture of the seat. Seats may come with an optional headrest.

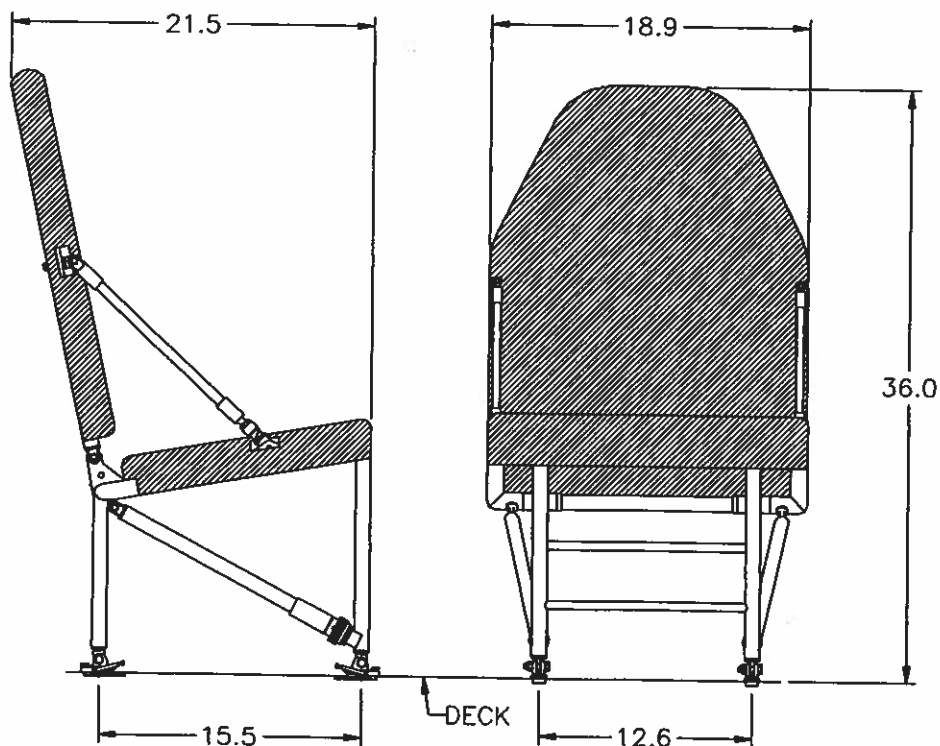

Figure 1.1.1 Basic Seat Dimensions. Optional Headrest Adds 8.0 Inches to Height.

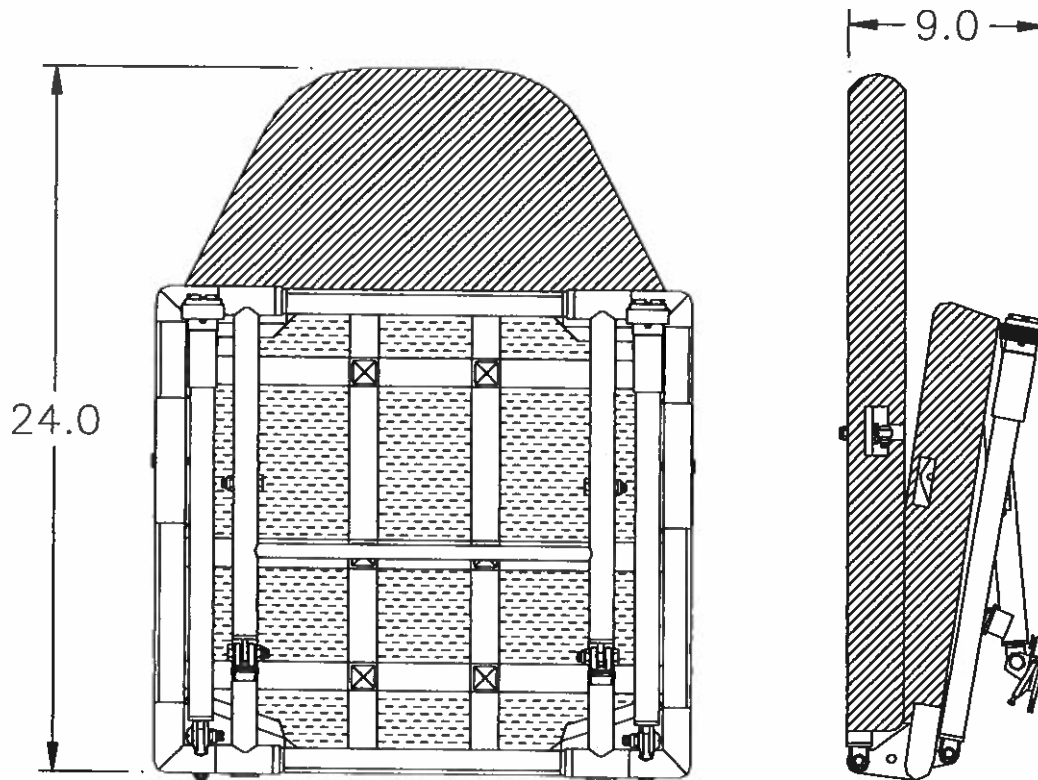

Figure 1.1.2 Folded Seat Dimensions. Optional Headrest Adds 8.0 Inches to Height.

1.2 Installation / Removal

NOTE: This seat is certified for forward-facing installation only.

This section describes general installation procedures; for information on allowable interior configurations, and corresponding weight and balance data see Section 1.4.

Before Aero Twin seats can be installed in the airplane, the following must be accomplished:

1. *The armrest/side panels must be checked for compatibility with Aero Twin seats. If the seats will not fit with the armrest/side panels installed, they must be removed from the inside of the fuselage walls. For removal instructions of these components refer to the aircraft maintenance manual.*

NOTE: Seats with the shoulder harness attached on the left side of the seat back must be installed on the left side of the airplane only. Seats with the shoulder harness attached

on the right side of the seat back must be installed on the right side of the airplane only. The following part numbers apply.

Left Seat P/N: DFS1-01W-L
Right Seat P/N: DFS1-01W-R

1.2.1 Setup and Installation (see Figure 1.2.1):

1. Unfold forward legs and lower diagonal arms. On each lower arm quick-release fitting, push in the retaining pin and retract the locking ring (detail 1, Figure 1.2.1). Position the arms to align fittings with studs on forward legs. Push forward leg back to engage studs in fittings, then extend locking rings to close jaws.

Be sure jaws close completely and retaining pins pop out to the extended (locked) position - Failure to properly engage studs and lock fittings could result in seat collapse.

2. Unfold seat back and upper diagonal arms. Position the arms so the quick-release fittings are over the corresponding pins on the seat frame. Retract the spring-loaded collar on one fitting, push the fitting over the pin, then release the collar. Repeat for the opposite side (detail 3, Figure 1.2.1).

Be sure the collars extend completely and the pins are properly captured in the fittings - failure to properly engage pins could result in seat collapse.

3. Unfold rear legs and position the seat over the seat tracks at the desired fuselage station. Drop the forward feet into the tracks (locking lugs must be in the retracted position), slide forward or aft 1/2 inch, and push the locking lugs down to lock the forward feet into the track (detail 2, Figure 1.2.1).
4. Extend the rear legs afterward to the built-in rotation stop, then move legs forward until aft feet can drop into the tracks. Slide feet aft 1/2 inch and push locking lugs down to lock feet in track. Locking lugs of rear feet should be 17 inches (17 track positions) aft of forward feet locking lugs.
5. The feet are equipped with anti-rattle devices. Use is optional. To use the anti-rattle feature, tighten the screw in the anti-rattle device until the stirrup is drawn snug against the seat track.
6. Connect the oxygen lines to the receptacles on the side wall.

Note: Aero Twin seats are not supplied with oxygen masks. Initial installation will require new masks to be purchased or the oxygen masks from the OEM seats to be transferred to the Aero Twin Seats.

7. Update aircraft empty weight and balance to account for seat installation (see Section 1.4).

1.2.2 Removal / Breakdown:

1. Disconnect the oxygen lines from the receptacle on the side wall.
2. Release anti-rattle feature on each of four feet (if feature is utilized).

3. Lift the rear feet locking lugs (a tool designed for this purpose is available from Aero Twin, Inc.). Slide the feet forward 1/2 inch and lift the feet from the track.
4. Repeat step 3 for the forward feet. Remove seat from tracks.
5. Push in the retaining pins and retract the locking rings of the lower diagonal arm quick-release fittings. Disengage the forward leg studs from the fittings.
6. **Fold the rear legs in first, then the forward legs.** Fold the lower arms into position alongside the forward legs.
7. Retract the spring-loaded collar on the quick release fitting on one of the upper diagonal arms and disengage the fitting from the pin on the seat frame. Repeat for the other arm.
8. Rotate and fold the upper arms inward across the seat back - note that the eyebolts in the seat back, to which the arms are attached, rotate in their bushings to accomplish this. The seat will fold best when the arms are positioned so that they do not cross each other.
9. Fold the back rest and seat base together.

NOTE: Track covers may not fit between installed Aero Twin seats, remove, modify or replace as necessary.

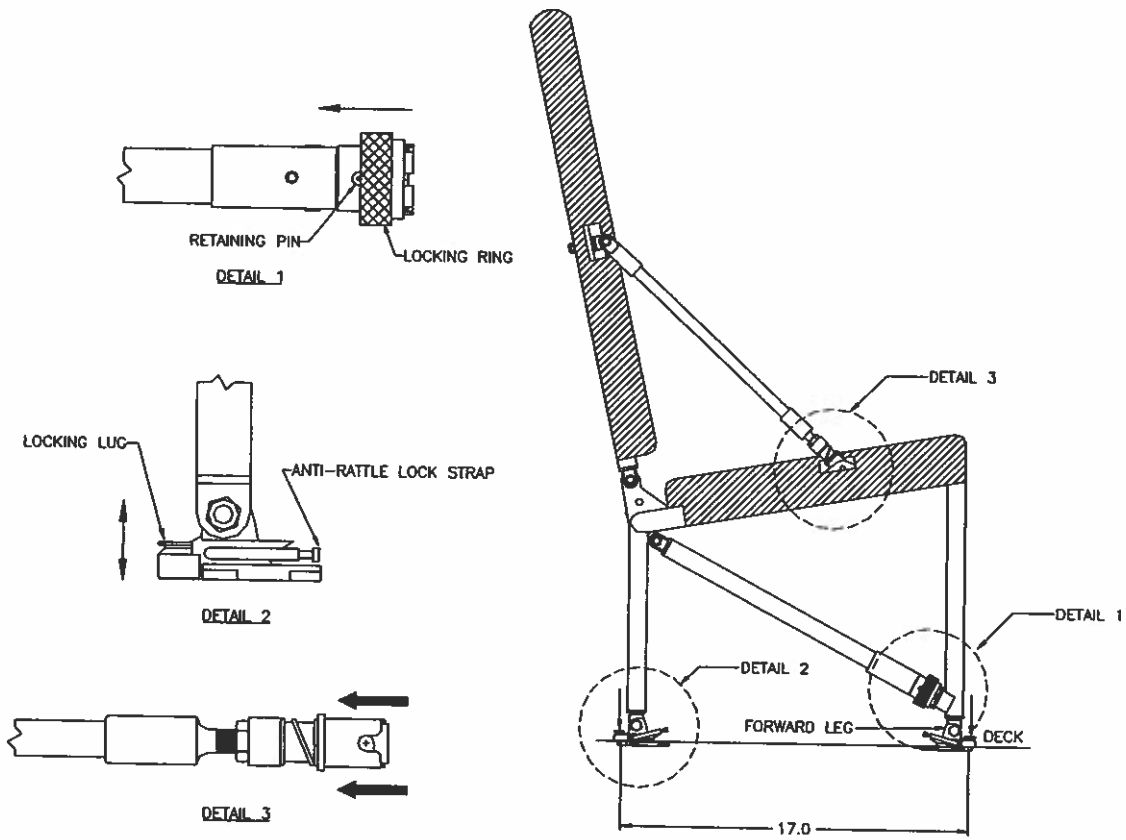

Figure 1.2.1 Seat Installation. Optional Headrest Not Shown.

1.3 Storage

A protective storage bag is available for these seats. For long-term storage it is recommended that the seat be placed in its protective bag. During storage the seats should be kept in a dry location away from any direct heat source.

The seats can be stacked up to six-deep in storage. Do not stack more than 100 lb. on top of a folded seat. Prior to installing a seat which has been in storage for an extended period, inspect and lubricate the seat in accordance with a 1000 hr/Annual inspection.

1.4 Weight and Balance

When seats are installed or removed, the aircraft empty weight and balance must be updated to reflect the configuration change. Weight and balance data is provided in sections 1.4.1 and 1.4.2.

Aero Twin seats may be installed in the PC-12 as direct replacements of the original Standard Single Seat. The seats may be installed in accordance with the various interior configurations defined by Pilatus in the AFM/POH with the exception: that Pilatus OEM seats may not be placed in a position directly behind an Aero Twin seat.

Verify correct placards are in place for the corresponding interior configuration. Any aircraft modifications required by Pilatus for a change to interior configurations must be completed per instructions available from Pilatus Aircraft.

1.4.1 Corporate Commuter 9 Pass. Seating Configuration (Pilatus interior code STD-9S)

The PC-12 standard 9-place seating configuration includes four seats located on the left side of the cabin and five on the right side. In this configuration the Aero Twin seats are installed with the front-leg locking lugs at the fuselage stations shown in Figure 1.4.1. The difference in installation fuselage stations between the Pilatus and Aero Twin seats is due to different measurement reference points on the seats (forward leg locking lugs instead of a center arresting pin). The Aero Twin seat forward feet locking lug must be installed 9 inches forward of the positions for the Pilatus seat center arresting pin.

Total weight, arm, and moment of 9 Aero Twin single place folding seats installed in the STD-9S configuration is as shown in the table below.

Weight and Balance Data for Aero Twin Inc. seats in STD-9S Configuration

(valid for 9 seat installation only)

Model	Weight (lb.)	Arm (F.S.)	Moment (in-lbs)
PC-12, PC-12/45, PC-12/47, PC- 12/47E	243 (without headrests)	271.65	66011 (without headrests)
	270 (with headrests)		73346 (with headrests)

For installing less than 9 seats, the weight, arm, and moment of the complete seat installation can be found as follows (method assumes all installed seats are the same) :

1. Record the fuselage station where the forward feet locking lugs of each installed seat are located (see sub-section 2.1 above).
2. Add all the recorded fuselage stations then divide the sum by the number of seats. Add 9.5 to the quotient. The result is the arm of the complete seat installation.
3. Multiply the number of seats by the appropriate individual seat weight. The result is the total weight of the seat installation.
4. Multiply the weight by the arm to arrive at the total moment.

PILATUS MODEL PC-12, PC-12/45, PC-12/47, PC-12/47E

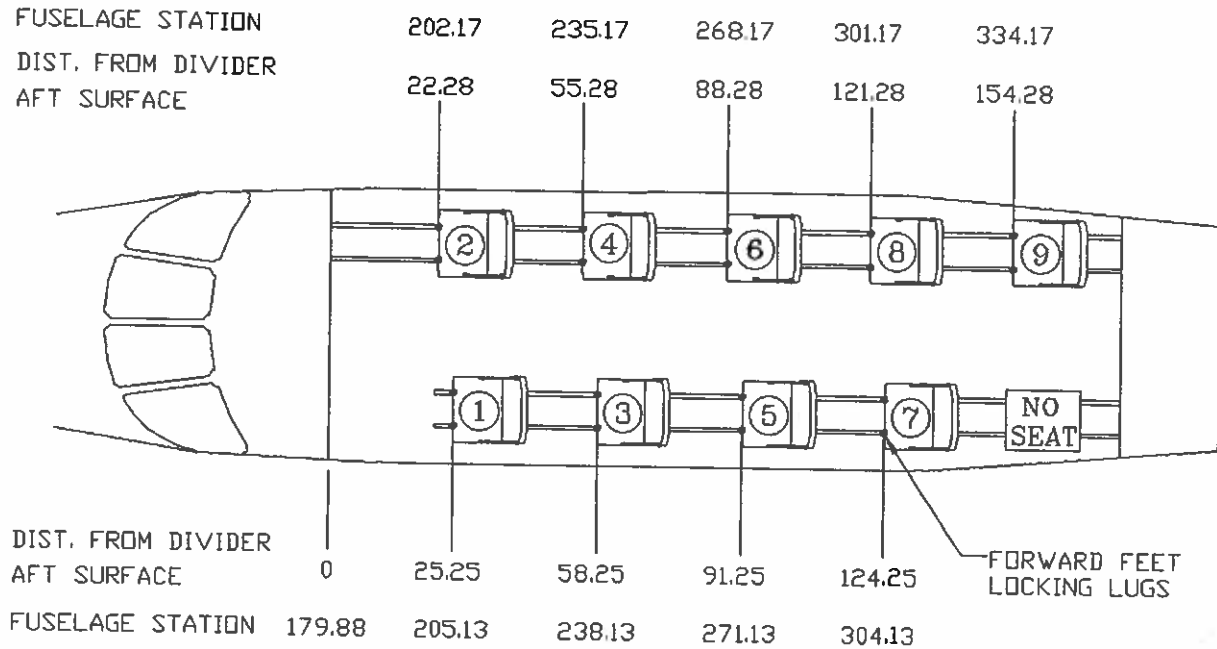

Figure 1.4.1
Aero Twin seats in the STD-9S Interior Configuration

1.4.2 Other seating configurations:

Aero Twin seats may be installed as a replacement for the OEM Standard Single seat in any interior configuration allowed by Pilatus. To determine the precise location for installation of Aero Twin seats, place the forward feet locking lugs 9 inches forward of the location given for the center arresting pin on the Pilatus standard single seat. *All restrictions and requirements regarding seat positioning and occupancy that apply to the OEM seats also apply to Aero Twin seats.*

Weight of one DFS1-01W seat assembly: 27 pounds without optional headrest
30 pounds with optional headrest

This includes all cushions and upholstery which, must be installed on the seat at all times when the aircraft is in operation.

For calculating weight and balance, individual seat center of gravity location is 9.5 inches aft of the forward feet locking lugs (see Figure 1.4.2).

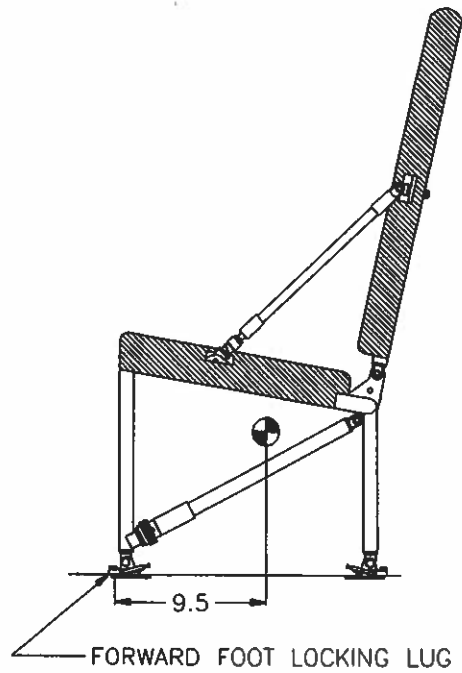

Figure 1.4.2
Seat Center of Gravity

Note: Seat spacing may not be less than 33 inches. The back rest of a seat may not be less than 33 inches from any object in front of it (see Fig. 1.4.3).

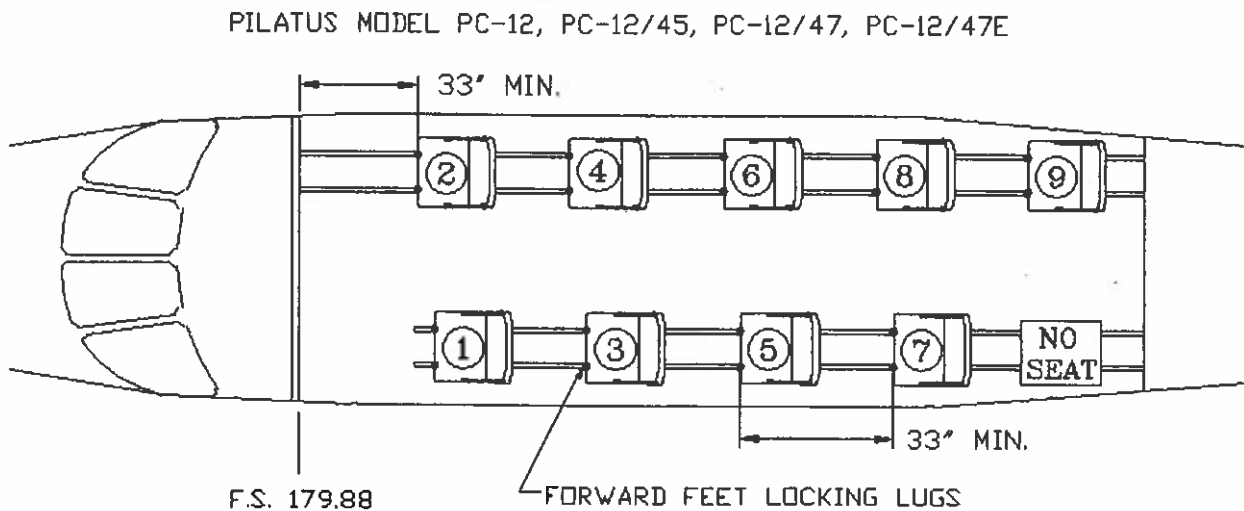

Figure 1.4.3
General Seat Locations and Spacing Requirements

1.5 Maintenance Instructions

1.5.1 General:

The Aero Twin Single Place Folding Seat is designed to be highly durable and fairly maintenance free. However, a maintenance program has been established, in accordance with Appendix G of FAR 23, to assure the continued airworthiness of the seats. Adherence to the established plan is mandatory and records of performance of required inspections and maintenance must be maintained. See Section 2.0, Airworthiness Limitations, for required maintenance items and intervals.

1.5.2 Cleaning:

1.5.2.1 Upholstery:

- For general dust and light dry soiling, vacuum upholstery thoroughly, and or brush with a clean stiff bristle brush. Avoid beating fabric as this can hasten wear and does not effectively clean the upholstery. Use of commercially available upholstery shampoo will remove most soil encountered in normal service. Follow product directions.
- For oil or grease stains, solvent-type cleaning agents can be effective. Test a small inconspicuous area of the fabric first. Use solvent-type agents sparingly, without saturating fabric. Apply with a clean soft cloth and work from the edge of the stain towards the center to avoid spreading. Observe appropriate safety precautions when using any solvent agent.
- For heavy, saturating stains (coffee, vomit, etc.) the upholstery cover should be removed and commercially dry-cleaned.

1.5.2.2 Seat Track:

The track should be kept clean, as dirt and contaminants can wear on the track and cause difficulty in installing and removing hardware. Cleaning may be done in a variety of ways as long as chemicals or tools used do not corrode or wear down the track.

1.5.2.3 Herculite fabric (seat pan and seat back cover):

Clean the Herculite fabric components using mild soap and water solution or a commercial vinyl cleaner. For heavy grease or oil stains, a diluted solution of Simple Green or equivalent cleaning solution can be used. Avoid excessive wetting of the fabric when installed on the seat, as moisture can collect between the fabric and tube structure and promote corrosion.

1.5.2.4 Metal Parts:

Moisten a clean soft cloth with a solvent-type cleaner or undiluted Simple Green or equivalent; thoroughly wipe metal parts completely clean. Wipe dry with a clean dry cloth. After heavy cleaning over or near lubricated joints, relubricate as appropriate.

1.5.3 Lubrication and Corrosion Prevention:

The hinged leg connections to the seat frame are areas that must be kept well lubricated and protected from moisture. *Corrosion X*TM is a product that is well suited to this dual purpose. This product is available from Aero Twin, Inc., or your local aviation supplier. Other commercial products are available that will perform well. WD-40 is not recommended, as its moisture displacement properties are inadequate.

The required maintenance procedures for the seat include lubrication and internal treatment of the steel tubes at specific intervals. The seat should also be lubricated if it is subjected to heavy moisture for any reason, or after thorough cleaning of the metal frame.

- To lubricate the rotating and sliding joints, spray lubricant into the joint while rotating or sliding the fitting (avoid over spray on the upholstery cover by first pulling the cover back from the joint). Wipe off all excess lubricant with a clean dry cloth.
- To internally treat the steel tubes, the upholstery cover and Herculite fabric seat pan and seat back cover should be removed. Using a small nozzle, spray *Corrosion X™* (or equivalent) into all available holes. Allow the frame to sit for several minutes to allow excess to drain as it may, then wipe off all external surfaces with a clean, dry cloth. Reassemble seat.
- If the painted surface of the steel tube structure is marred in service or during handling, the affected area should be repainted to prevent corrosion. See instructions in section 1.5.5.3.

1.5.4 Disassembly / Assembly:

1.5.4.1 Disassembly:

- To remove the optional headrest, reach up through the opening in the bottom of the backrest cover and remove the lock pin from the right hand headrest slider tube. Pull headrest up out of seat back.
- To remove the padded upholstery backrest cover, the shoulder harness and optional headrest must be removed. Pull the flap free from the Velcro® strips on the lower part of the back rest, then slide the cover up and off the back.
- To remove the seat cushion and upholstery: disconnect the 3 flaps from the Velcro® strips on the sides and front of the seat pan. Pull the cushion and upholstery forward off the pan.
- To remove the Herculite seat back cover, loosen and release the strap buckles on the aft side of the seat, then slide the cover off of the seat back frame.
- To remove the Herculite seat pan, remove the screws from the underside of the seat frame.
- Disassembly of the seat frame is straightforward, as all connections utilize standard aircraft hardware.

1.5.4.2 Assembly:

Refer to the Illustrated Parts List when reassembling the seat frame.

Replace self-locking type nuts with new hardware when reassembling seat.

Any time the Herculite seat pan is removed, use new screws for reinstallation.

Use standard torques except as follows:

- The nuts, which retain the lap belts, should be snug but not over-tight to allow rotation of the lap belt fittings.
- The nuts on the clevis bolts at the upper ends of the two arm assemblies, and the nuts that retain the two eyebolts to which the arms attach, should be snug but not over-tight to allow rotation of the arms for folding.
- The nuts and bolts which attach the feet (seat track fittings) to the eyebolts at four locations should not be tightened so much as to cause distortion of the cast lugs on the fitting.

1.5.4.3 Adjustments:

- Arm Assemblies: These members are not adjustable.
- Headrest: If optional headrest does not stay in place when adjusted up and down in the seat back, remove the headrest per section 1.5.4.1 and manually flex headrest slider tubes outward until they provide resistance when installed in the seat back. Replace headrest with lock pin.

1.5.5 Seat Repair:

1.5.5.1 Hardware Replacement:

Hardware used throughout the seat is aircraft standard. Hardware should be replaced if corroded, damaged, or excessively worn. Replace self-locking type nuts with new hardware when reassembling seat. Do not substitute hardware - refer to the Illustrated Parts List for correct part numbers. If you encounter difficulty procuring replacement hardware or fittings, contact Aero Twin, Inc. at (907) 274-6166. Refer to previous section for assembly information.

1.5.5.2 Quick Release Fittings

Quick release fittings should be replaced or repaired *immediately* if components are missing, or parts are corroded, damaged or excessively worn. Missing components of a quick release fitting constitutes an un-airworthy seat. Replacement fitting parts can be procured through Aero Twin Inc. at the number listed in section 1.5.5.1.

1.5.5.3 Steel Tube Frame:

Before any repairs may be made to the steel tube frame, written approval must be obtained from the manufacturer, Aero Twin Inc. Contact Aero Twin Engineering Department at (907) 274-6166 or write: Aero Twin Inc., Engineering Dept., 2404 Merrill Field Dr., Anchorage AK, 99501.

NOTE: Arm Assemblies (P/N DFS1-02W), are not eligible for repair. If these parts are found to be bent or cracked, they must be discarded and replaced.

1.5.5.4 Painted Surfaces:

Painted steel surfaces should be maintained and refinished as required to prevent corrosion. When refinishing is required, lightly sand the affected area using fine sandpaper or an abrasive pad (such as 3M *Scotch-Brite*[™]). Polish out minor surface nicks or scratches where present. Clean the area thoroughly with a clean cloth wetted with non-petroleum-based solvent to remove any residual oils and dust. Apply a zinc-chromate or equivalent primer coat, then a matching color coat of quality enamel or epoxy-type paint. Follow manufacturer's instructions in preparing and applying primer and color coats.

1.5.5.5 Fabric:

- Herculite Components: These components are subject to mandatory replacement at fifteen-year intervals, but should be replaced when found to be excessively worn, frayed, or torn. Open seams can be re-stitched using nylon thread.
- When replacing the Herculite seat pan with a new assembly:

- Ensure that metal strips in edge are positioned in their pocket with the outside edge against the fold of the pocket.
- Position the seat pan on the metal frame with the existing screw holes centered in both the metal strips and the nylon webbing.
- Match drill the seat pan to the existing screw holes using a #32 drill bit and secure the pan to the frame using S1021A6-8 or MS51863-23C screws.
- Upholstery: Re-stitch open seams using nylon thread. Small tears can be drawn closed and sewn. Extensive damage usually justifies replacement of the upholstery cover.
- Foam: The seat is not approved for operation without the foam supplied with the seat, or equivalent. Padding should only be replaced with medium density highly damped, semi-reticulated urethane foam. Confor Foam CF-45 (bottom layer), CF-40 (middle layer), and DAX-55 scrim (top layer) are acceptable replacements.

1.5.5.6 Restraint Belts:

The belt assemblies are subject to mandatory replacement at twelve-year intervals. Worn, frayed, cut, or otherwise damaged belt assemblies should be replaced or remanufactured immediately by a qualified repair station. Any belt assembly that is found to be missing its manufacturer's data patch must be considered unairworthy and must be replaced.

1.5.5.7 Oxygen Masks (if installed)

Repair or replace in accordance with the instructions specified in the PC-12, PC-12/45, PC-12/47, or PC-12/47E maintenance manual or according to manufacturers instructions.

1.5.5.8 Seat Feet:

The seat track fittings that serve as seat feet use a plunger that slides up and down on a steel body and locks into the seat track when pushed down. A retaining pin is in the front of the body that is pushed out by a small spring to sit in a groove inside the plunger. The pin keeps the plunger from falling off the bottom of the body. Sometimes the plunger can be jarred out of place and the pin, spring, and ball that the spring seats on are lost. A repair kit, ATI-40566-R, is available, which provides replacement pins, springs, and balls. Later seat feet incorporate a roll pin to further restrict the plunger from falling off the bottom of the body

2.0 Airworthiness Limitations

Aero Twin, Inc. Single Place Folding Seat P/N DFS1-01W

The Airworthiness Limitations section is FAA approved and specifies maintenance required under paragraphs 43.16 and 91.403(c) of the Federal Aviation Regulations unless an alternative program has been FAA approved.

This section describes required inspection, maintenance, and replacement items. When repairs are deemed necessary, follow accepted standard practices and/or specific maintenance instructions in Section 1.5 of this manual. This section constitutes Component Airworthiness Limitations which apply to the seat only.

2.1 Scheduled Inspections and Maintenance:

Note: First inspection should be accomplished at next aircraft inspection so that subsequent inspections coincide.

2.1.1 1000 hour or Annual Inspection:

Remove padded upholstery cover.

Inspect steel tube frame:

 Tubes for bends, dents, corrosion, or other defects.

 Welded areas for cracks or other defects.

 Finish for scratches, abrasion, etc.

Inspect hardware and fittings:

 Hardware for security and condition.

 Quick-release fittings for proper operation and condition.

 Feet (track fittings) for proper operation, security, and condition.

Inspect Herculite fabric (seat pan and seat back cover):

 Fabric for wear, fraying, tearing, or other defects

 Attachment screws (seat pan) for security

 Straps and buckles (seat back) for condition and tautness

Inspect restraint system (lap belts and shoulder harness assemblies):

 Webbing for cuts, fraying, or other defects.

 End fittings for security and condition.

 Buckles for proper operation.

 Data patches (must be present and legible).

Inspect overall seat assembly and upholstery for cleanliness and general airworthiness.

Lubricate all rotating and sliding parts fittings (Corrosion X™ or equivalent).

Reinstall padded upholstery cover.

FAA Approved: _____

August Casey

Date: _____

2/1/13

3.0 Illustrated Parts List

Aero Twin, Inc. Single Place Folding Seat P/N DFS1-01W

3.1 Complete Parts List:

Item	Qty (per seat)	Part Number	Description	Appears on Fig:
1	1	DFS1-05W	Seat Pan Frame	3.2, 3.6
2	1	DFS1-04(-L/-R)	Back Rest Frame	3.2
3	2	DFS1-02W	Lower Arm	3.2, 3.3, 3.5
4	2	DFS1-03	Upper Arm	3.2
5	1	DFS1-06(H)(L/R)	Back Rest Cover	3.2
6	1	DFS1-35	Seat Cushion	3.2
7	4	ATFS-133	Buckle	3.2
8	A/R	NAS1149F 0532P/0563P	Washer	3.2, 3.3, 3.4
9	4	AN25-14A or AN5-10A	Clevis Bolt	3.2, 3.3
10	4	AN5-11A	Bolt	3.3
11	4	ATI-SFT-14 or -15	Retainer	3.3
12	2	MS20392-3C35	Clevis Pin	3.3
13	2	MS24665-132	Cotter Pin	3.3
14	1	DFS1-06-2	Seat Back Cushion	3.2
15*	1	5-01-820701 (LH) 5-01-825701 (RH)	Lap Belt and Shoulder Harness Assembly	3.4
16	4	ATFS-62L	Eye Bolt	3.2, 3.3
17	A/R	NAS1149F 0432P/0463P	Washer	3.4
18	1	S1003-9A	Bushing	3.4
19	1	AN24-24A	Bolt	3.4
20	2	AN5-7A	Bolt	3.4
21	2	ATFS-115A	Flanged Bushing	3.4
22	1	MS21083N4	Nut	3.4
23	2	AN5-7A (Alt. AN5-9A)	Bolt	3.4
24	4	MS21083N5	Nut	3.2, 3.3, 3.4
25	4	NAS561P8-16	Roll Pin	3.5
26	2	MS22034-1 /IB	Retainer Fitting	3.5
27	20	MS51863-23/23C, S1021A6-8	Screw	3.2, 3.6
28	1	DFS1-07W	Seat Pan	3.6
29	1	DFS1-36	Oxygen Mask Bag	3.6
30	1	DFS1-06-03	Seat Back Cushion Upholstery	3.2
Accessories:				
31	1 (Optional)	DFS1-33	Headrest	3.2
32	1 (Optional)	AA55487-2	Lock Pin	3.2
N/A	N/A	ATFS1-09	Storage Bag	(not shown)
N/A	N/A	AT-SRT-01	Removal Tool	(not shown)
N/A	N/A	AT-40566-R	Seat Foot Repair Kit	(not shown)

*Item -15: Older S/N seats may have P/N 5-01-510701RevA (LH) or 5-01-515701RevA (RH) installed. For service on these older parts, order P/N 5-01-820701 (LH) or 5-01-825701 (RH).

3.2 FOLDING SEAT OVERVIEW & BACK REST COVER INSTALLATION

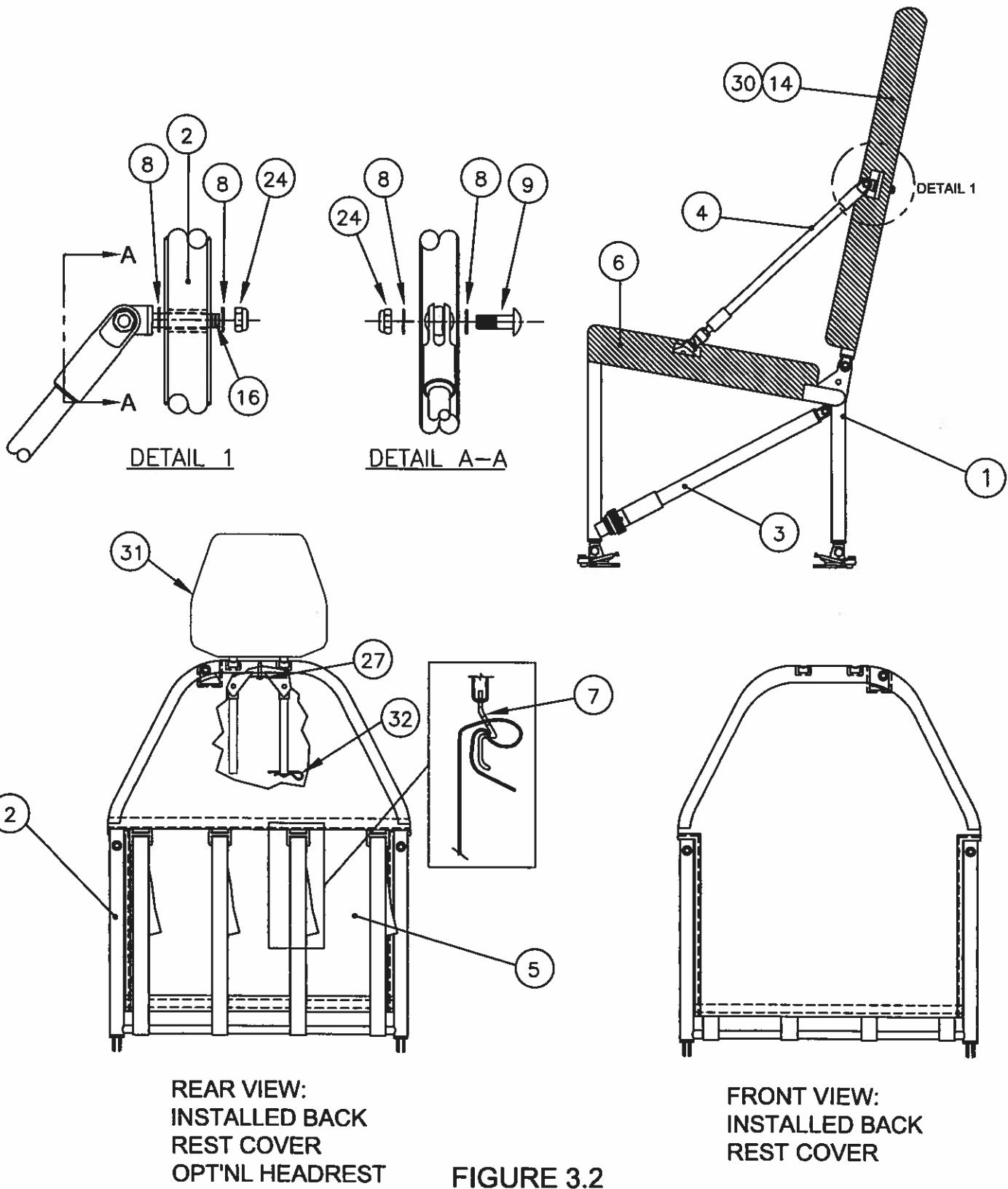

3.3 SEAT BOTTOM HARDWARE & LOWER ARM INSTALLATION

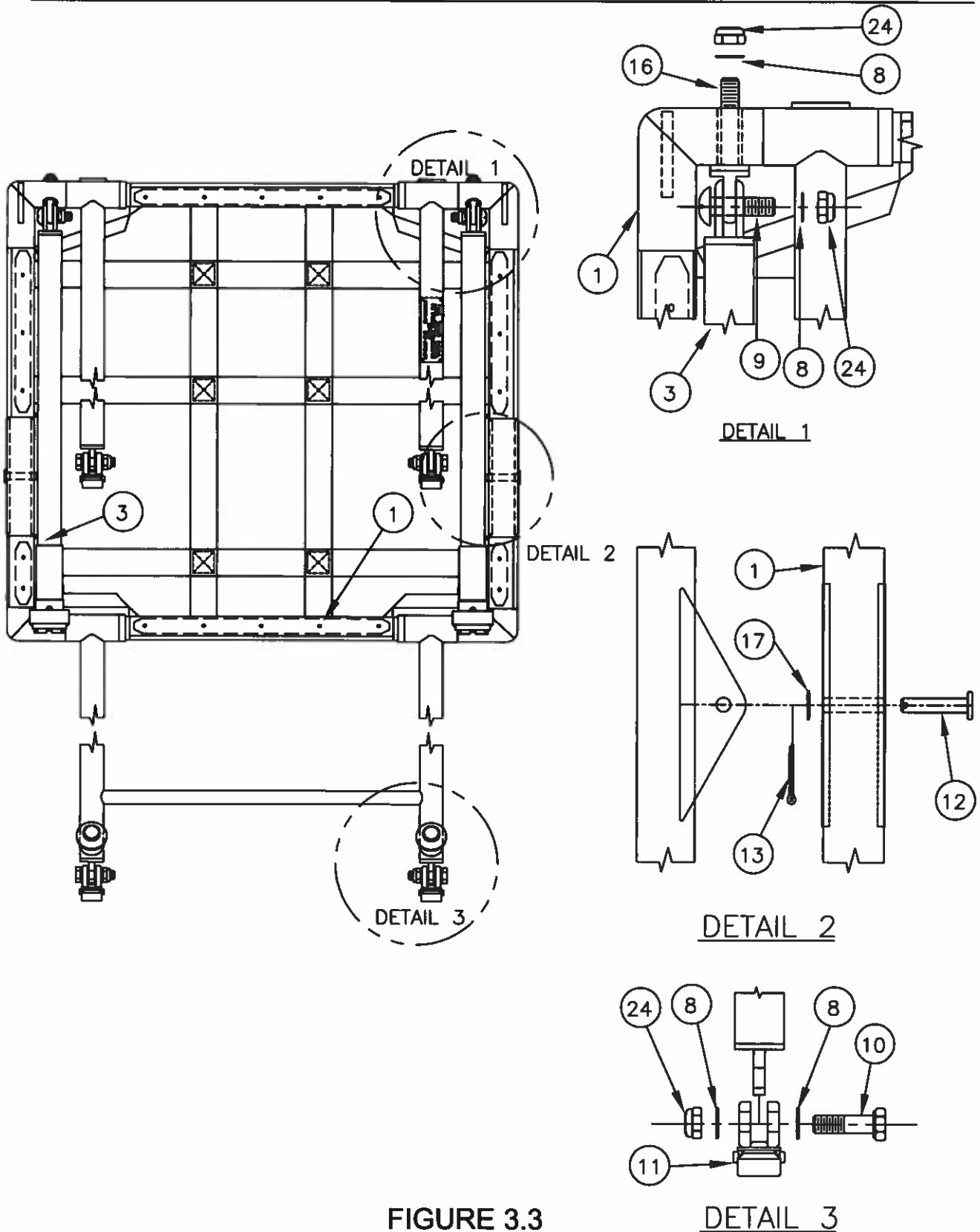

FIGURE 3.3

3.4 SEAT BELT AND BACK INSTALLATION

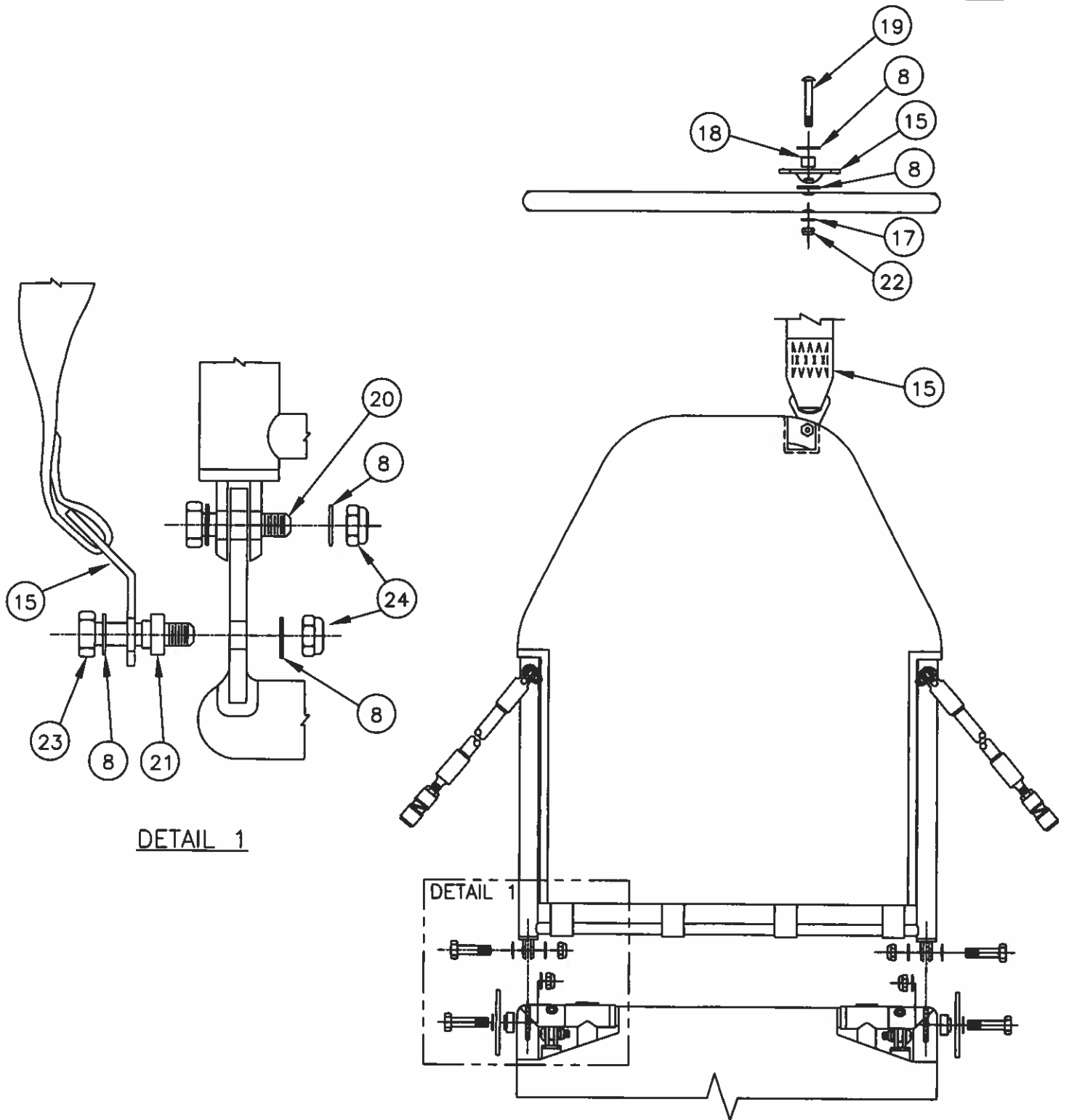

FIGURE 3.4

3.5 LOWER ARM DETAIL

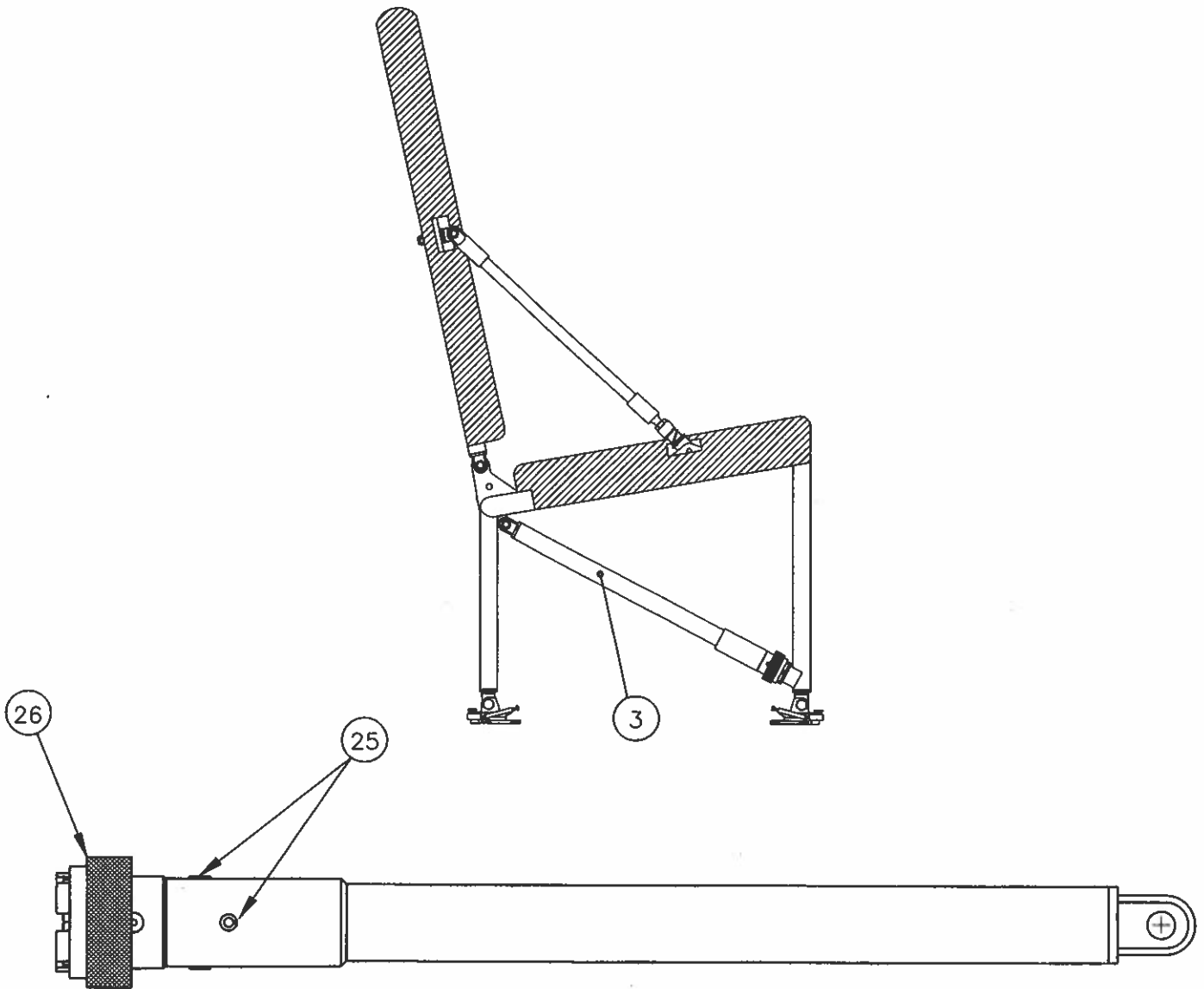

FIGURE 3.5

3.6 SEAT PAN INSTALLATION

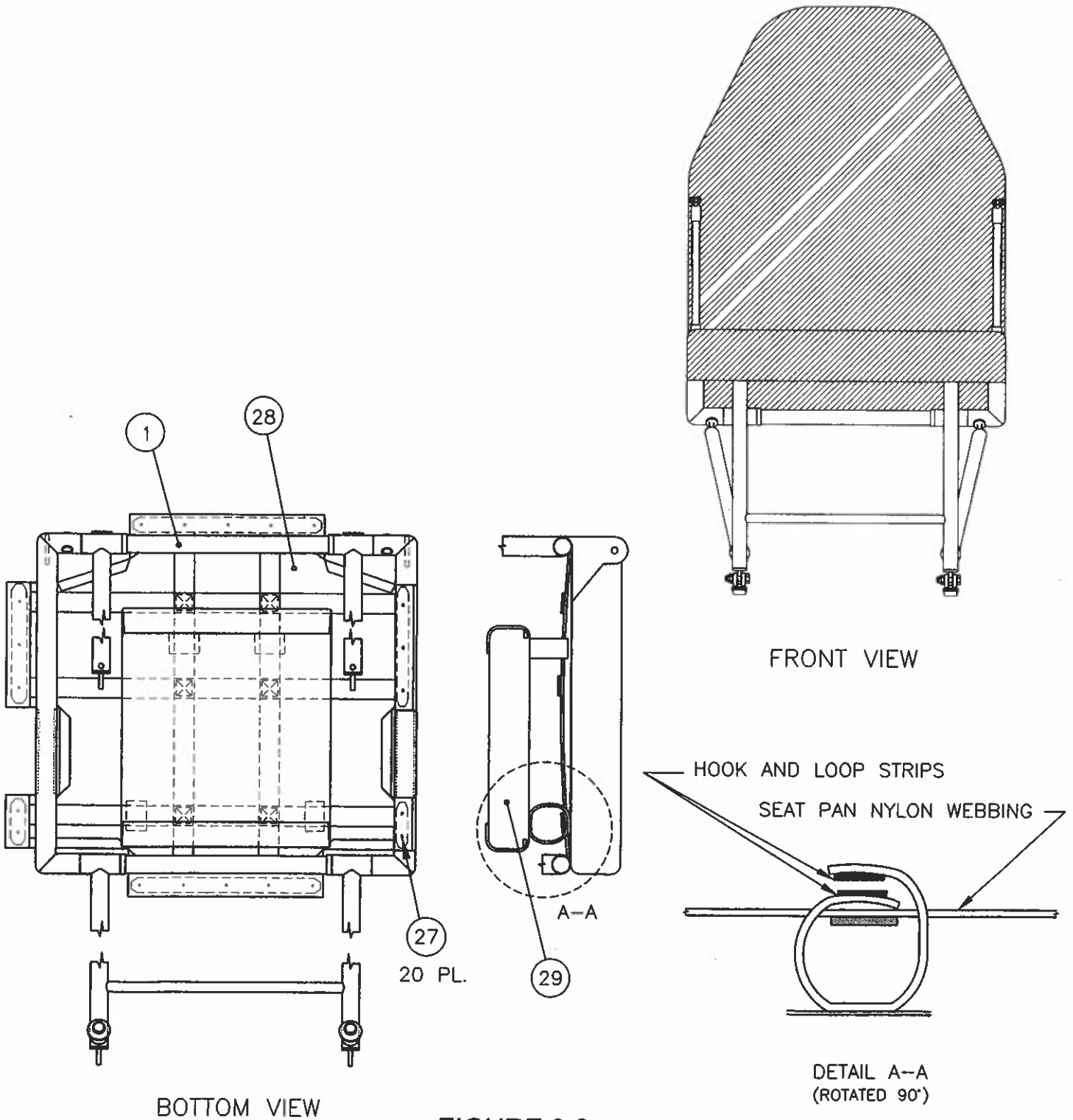

FIGURE 3.6