

**Aero Twin, Inc. Single Place Folding Seat
P/N ATFS1-01 standard version
P/N ATFS1-01S flightseeing version
for
Cessna Model 208, 208B Caravan Aircraft**

**INSTRUCTIONS FOR CONTINUED
AIRWORTHINESS**

Document No. ATFS1-ICA1

Maintenance Manual
Airworthiness Limitations
Illustrated Parts List

FAA/DAS Approved:



DAS Coordinator
Designated Alteration Station DAS-01-AK
Anchorage, Alaska

FAA/DAS Approved:



DAS Airworthiness Inspector
Designated Alteration Station DAS-01-AK
Anchorage, Alaska

Date: March 31, 1995

LOG OF REVISIONS			
REVISIONS		PAGES REVISED AND DESCRIPTION OF REVISIONS	APPROVAL SIGNATURE
NO.	DATE		
--	3/31/95	Original Issue	Michael Lovett
A	3/1/96	Pages 2,5,7, and 17 through 22; Pages revised in accordance with ECO AT-34	
B	10/1/96	Pages 2-4, 13, 16, 17, 19 & 22; Pages revised in accordance with ECO AT-44	
C	06/29/99	Pages 2, 17, 19, 21, & 22; Pages revised in accordance with ECO AT-54	
D	12/15/99	Pages 2, 7, & 15- 22 revised in accordance with ECO AT-56	Michael Lovett
E	07/06/05	Page 22 revised in accordance with ECO AT-109	KMT
F	04/02/12	Pages 2, 6-8, 13-17, & 19-22 revised in accordance with ECO AT-147	JMK
G	05/14/13	Pages 2, 6, 7, 13, 16-19, 21, & 22 revised in accordance with ECO AT-152	JMK
H	12/24/13	Pages 2, 4, 9, 11, 17, & 20 revised in accordance with ECO AT-160	JMK
I	05/07/18	Pages 2, 4, 14, 17, 19, 21, and 22 revised in accordance with ECO AT-174	

Information in this publication is based on data available at the time of publication and may be updated, supplemented, and automatically amended by a revision or re-issuance. All such amendments become part of and are specifically incorporated within this publication. Users are urged to keep abreast of the latest amendments to this publication through information available on Aero Twin, Inc.'s website, <http://www.aerotwin.com>. The latest revision of the Instructions for Continued Airworthiness for all of Aero Twin, Inc.'s products are available for download at that website.

Table of Contents

Section	Page
Log of Revisions.....	2
Table of Contents	3
1.0 Maintenance Manual	4
1.1 Description.....	4
1.2 Installation/Removal.....	6
1.3 Storage.....	8
1.4 Weight and Balance.....	8
1.5 Maintenance Instructions	11
2.0 Airworthiness Limitations.....	15
3.0 Illustrated Parts List.....	17
3.1 Complete Parts List	17
3.2 Upper & Lower Arm Assemblies	18
3.3 Back Rest Cover and Upper Arm Installation	19
3.4 Seat Back, Lap Belt, and Harness Installation	20
3.5 Seat Bottom Hardware & Lower Arm Installation	21
3.6 Seat Bottom Cover & Foot Installation.....	22

1.0

Maintenance Manual

Aero Twin, Inc. Single Place Folding Seat P/N ATFS1-01 standard version P/N ATFS1-01S flightseeing version

1.1 Description

The Aero Twin single place folding seat for the Cessna 208 Caravan is designed for quick and easy installation and removal, and for compact stowage when not in use.

The basic structure of the seat is a 4130 steel tube welded frame. The seat back and legs fold for storage. Four diagonal arms, each hinged at one end and equipped with a quick-release fitting at the other, provide primary structural support for the installed seat. Optional armrests, when installed, are integral with the upper diagonal arms. Also, a tapered seat back option is available to allow for a wider walking aisle. The seat pan is rubber-impregnated high-strength fabric attached to the seat frame with aluminum inserts using sheet-metal screws. The seat back cover is of the same material; it slides over the seat back frame and is secured with nylon straps. Occupant restraint is provided by a lap belt and single diagonal shoulder harness, all attached to the seat frame. The seat is equipped with four identical anti-rattle type track fittings that engage the standard Caravan seat tracks. A one-piece padded upholstery cover is supplied with most seats as standard; this slides over the seat frame and is secured with hook-and-loop strips. Optionally, a 2.5 inch cushion and alternative upholstery is available. The seat can be used without any upholstery cover or cushions if desired. Additionally, an optional seat slip cover is available to provide an easily removable protective cover for the upholstery. The seat is identified by a data plate permanently attached to the forward leg cross-member. The data plate lists the part number, serial number, and date of manufacture of the seat. The flight seeing version has 2 inch shorter rear legs and 1 inch shorter front legs.

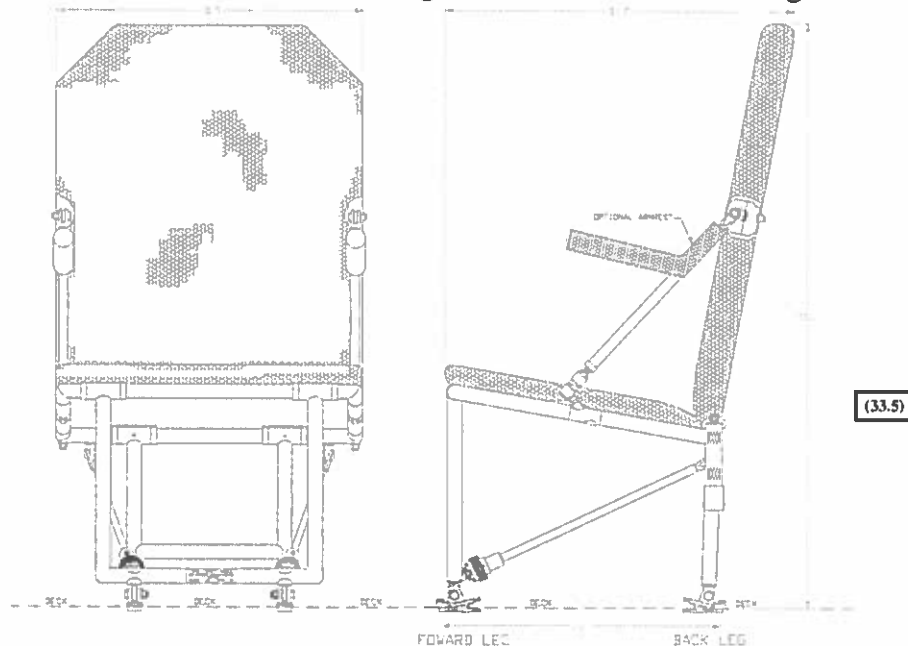

Figure 1.1.1 Basic Seat Dimensions

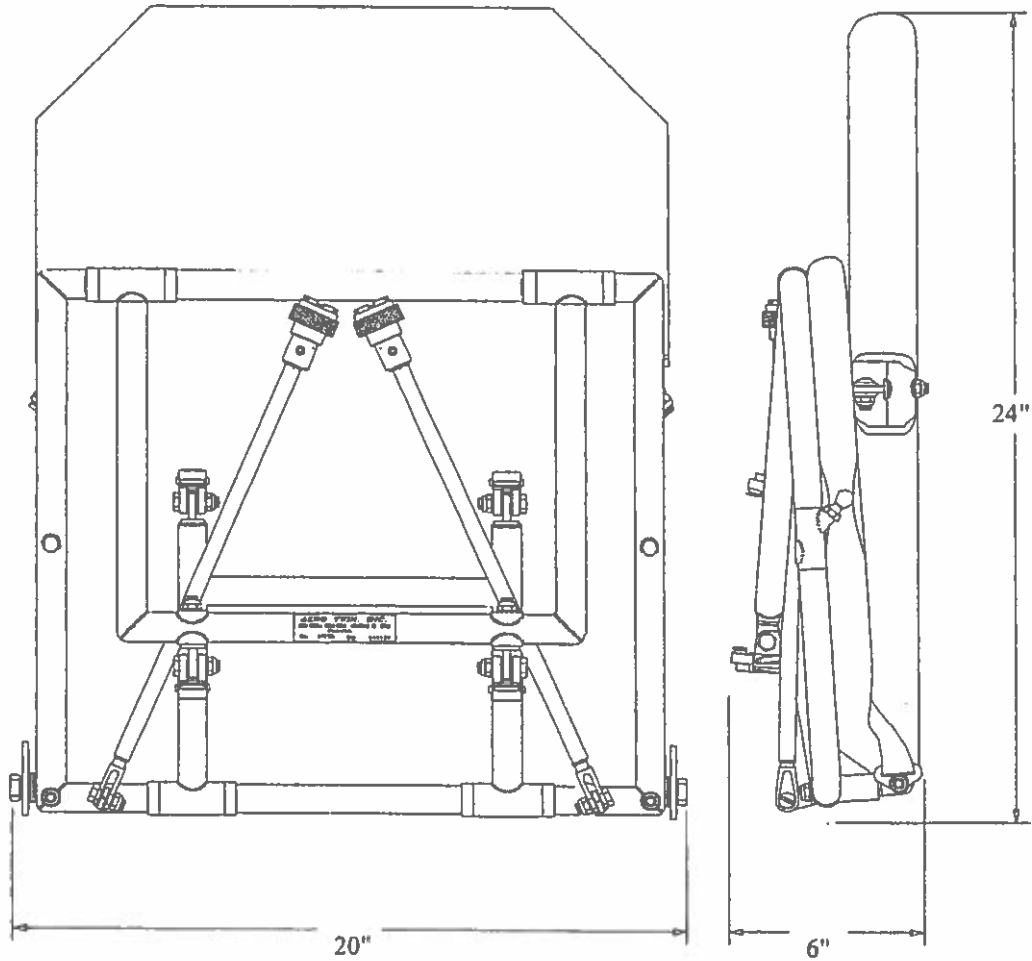

Figure 1.1.2 Folded Seat Dimensions

1.2 Installation / Removal

NOTE: This seat is certified for forward-facing installation only.

This section describes general installation procedures; for information on standard or non-standard seat locations and corresponding weight and balance data, see Section 1.4.

1.2.1 Setup and Installation:

1. Unfold forward leg and lower diagonal arms. On each quick-release fitting (item -104), push in the retaining pin and retract the locking ring (see detail in Figure 1.2.1). Position the diagonal arms to align fittings with studs (item -109) on forward leg. Push forward leg back to engage studs in fittings, then extend locking rings to close jaws.

Be sure jaws close completely and retaining pins pop out to the extended (locked) position - Failure to properly engage studs and lock fittings could result in seat collapse.

2. (ATFS1-01 thru S/N 1599, ATFS1-01S thru S/N 637) Unfold seat back and upper diagonal arms. Position the arms so the quick-release fittings (item -106) are over the corresponding studs (item -113) on the seat frame. Retract the spring-loaded collar on one fitting, push the fitting onto the stud, then release the collar. Repeat for the opposite side.

Be sure the collars extend completely and the studs are properly captured in the fittings - failure to properly engage studs could result in seat collapse.

2. (ATFS1-01 S/N 1600 and on, ATFS1-01S S/N 638 and on) Unfold seat back and upper diagonal arms. Position the arms so the quick-release fittings (item -106) are over the corresponding clevis pin (item -08) on the seat frame. Retract the spring-loaded collar on one fitting, push the fitting onto the pin, then release the collar. Repeat for the opposite side.

Be sure the collars extend completely and the clevis pins are properly captured in the fittings - failure to properly engage pins could result in seat collapse.

3. Unfold rear leg and position the seat over the seat tracks at the desired fuselage station. Drop the forward feet into the tracks (locking lugs must be in the retracted position), slide forward or aft 1/2 inch, and push the locking lugs down to lock the forward feet into the track.
4. Extend the rear legs afterward to the built-in rotation stop, then move legs forward until aft feet can drop into the tracks. Slide feet aft 1/2 inch and push locking lugs down to lock feet in track. Locking lugs of rear feet should be 16 inches (16 track positions) aft of forward feet locking lugs.
5. The feet are equipped with anti-rattle devices. Use is optional. To use the anti-rattle feature, tighten the screw in the anti-rattle device until the stirrup is drawn snug against the seat track.
6. If optional armrests are installed, rotate armrest into position and allow armrest sleeve to drop into position over the pin.
7. Update aircraft empty weight and balance to account for seat installation (see Section 1.4).

1.2.2 Removal / Breakdown:

1. Release anti-rattle feature on each of four feet (if feature is utilized).
2. Lift the rear feet locking lugs (a tool designed for this purpose is available from Aero Twin, Inc.). Slide the feet forward 1/2 inch and lift the feet from the track.
3. Repeat step 2 for the forward feet. Remove seat from tracks.
4. Push in the retaining pins and retract the locking rings of the lower diagonal arm quick-release fittings. Disengage the forward leg studs from the fittings.
5. Fold the rear legs up, then the forward legs. Fold the arms into position alongside the forward legs.
6. Retract the spring-loaded collar on the quick release fitting on one of the upper diagonal arms and disengage the fitting from the stud (or clevis pin) on the seat frame. Repeat for the other arm.
7. If the optional armrests are installed, lift each armrest to disengage from its retaining pin, then rotate inward.
8. Rotate and fold the upper arms inward across the seat back - note that the eyebolts in the seat back, to which the arms are attached, rotate in their bushings to accomplish this. The seat will fold best when the arms are positioned so that they do not cross each other.
9. Fold the seat back down.

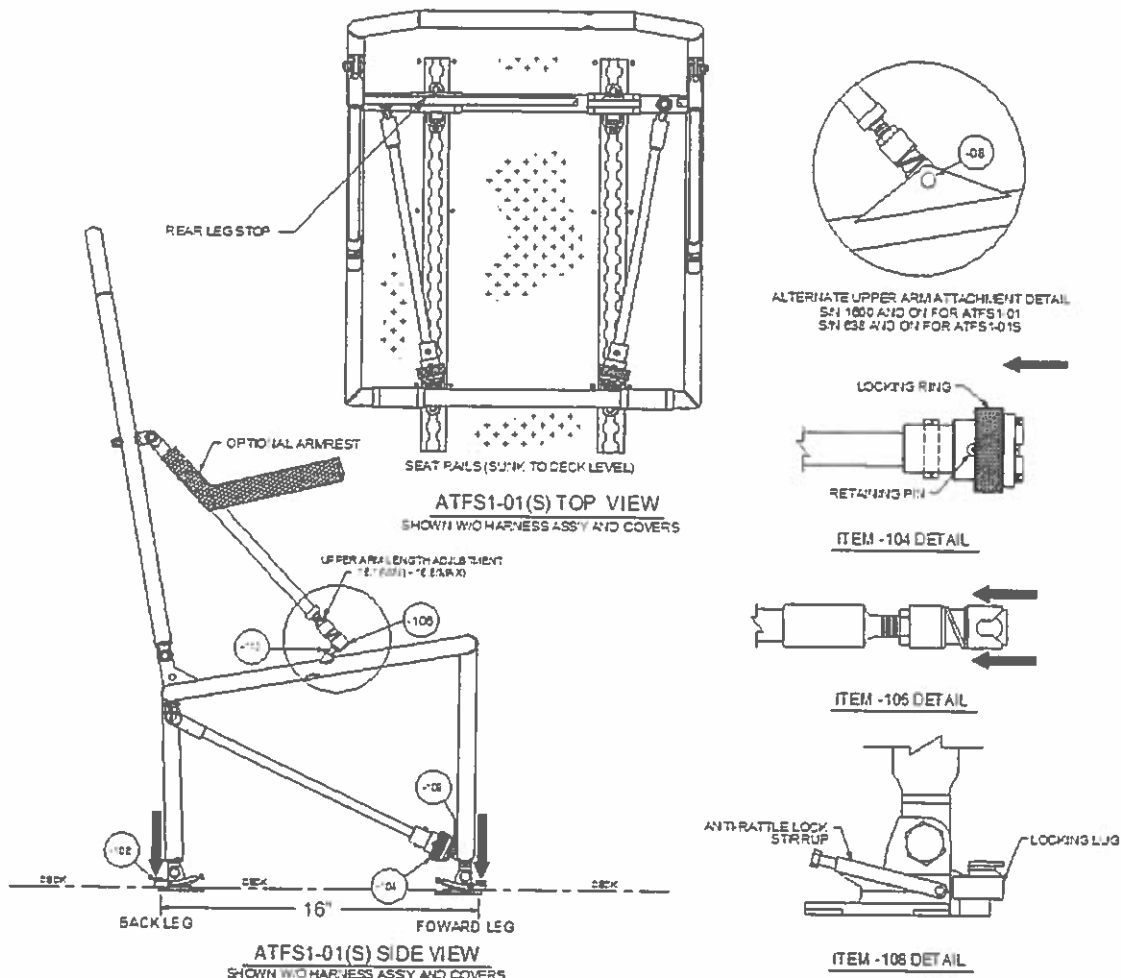
**Figure 1.2.1 Seat Installation**

1.3 Storage

A protective storage bag is available for these seats. For long-term storage it is recommended that the seat be placed in its protective bag. During storage the seats should be kept in a dry location away from any direct heat source.

The seats can be stacked up to six-deep in storage. Do not stack more than 100 lb. on top of a folded seat.

Prior to installing a seat which has been in storage for an extended period, inspect and lubricate the seat in accordance with a 1,000 hr/Annual inspection.

1.4 Weight and Balance

When seats are installed or removed, the aircraft empty weight and balance must be updated to reflect the configuration change. Weight and balance data for a standard 10-place seating configuration is provided in section 1.4.2. For alternate seating configurations, see section 1.4.3.

1.4.1 General:

To facilitate locating fuselage stations in the cabin, Model 208B aircraft have single digit numbers (e.g. 6, 8, 0, etc.) on the seat tracks. The numbers 6, 8, 0, etc. refer to fuselage stations 160, 180, 200, etc. Where these reference numbers do not exist or are unreadable, the forward face of the raised aft cargo floor can be used as a reference. This face is located at station 284 in the Model 208, or at station 332 in the Model 208B.

1.4.2 Standard 10-Place Seating Configuration:

The standard 10 place seating configuration includes four seats located on the left side of the cabin and four on the right side (plus pilot and front-seat passenger). In this configuration the passenger seats are installed with the front-leg locking lugs at the fuselage stations shown in Figure 1.4.1. Note that these positions are identical to the standard 10-place utility configuration seat positions recommended by Cessna. Some Model 208 Caravans have "X"s stamped on the cabin seat tracks to indicate the correct locations of the seat forward feet. Note: the aft right-hand seat may require back-rest adjustment to clear the ladder assembly on the closed door.

Total weight, arm, and moment of eight Aero Twin single place folding seats installed in the standard 10-place configuration is as shown in the table below:

Weight and Balance Data for Standard 10-Place Seating Configuration

Model	Weight (lb.)*		Arm (in)	Moment/1000	
	w/o Armrest	with Armrest		w/o Armrest	with Armrest
Model 208:	160	180	211	33.8	38.0
Model 208B:	160	180	228	36.5	41.0

*If upholstery covers are removed, subtract 24 lb. from weights and recalculate moments (change in arm is negligible).

1.4.3 Alternate Seating Configurations:

When installing Aero Twin single place folding seats in a configuration other than the standard configuration, the effect on aircraft empty weight and moment must be determined for that configuration.

Individual seat weights are as shown below:

- Upholstery Cover Installed, w/o Armrests: 20 lb.
- Upholstery Cover Removed, w/o Armrests: 17 lb.
- Upholstery Cover Installed, with Armrests: 22.5 lb.
- Upholstery Cover Removed, with Armrests: 19.5 lb.

Note: Fightseeing version P/N ATFS1-01S weighs 3 ounce less than standard version P/N ATFS1-01. Weight and balance change between standard version and fightseeing version is considered negligible.

The optional seat slip covers add 2.5 pounds to each seat.

Individual seat center of gravity location is 10.5 inches aft of the forward feet locking lugs.

For any arbitrary seating configuration, the weight, arm, and moment of the complete seat installation can be found as follows (method assumes all installed seats are the same) :

1. Record the fuselage station where the forward feet locking lugs of each installed seat are located (see sub-section 1.4.1 above).
2. Add all the recorded fuselage stations then divide the sum by the number of seats. Add 10.5 to the quotient. The result is the arm of the complete seat installation.
3. Multiply the number of seats by the appropriate individual seat weight. The result is the total weight of the seat installation.
4. Multiply the weight by the arm to arrive at the total moment. Divide the moment by 1000 to incorporate with the basic aircraft weight and balance data.

Note: When seats are installed in a non-standard configuration, the pilot or operator must be informed of actual seat locations so that passenger loading data can be correctly calculated.

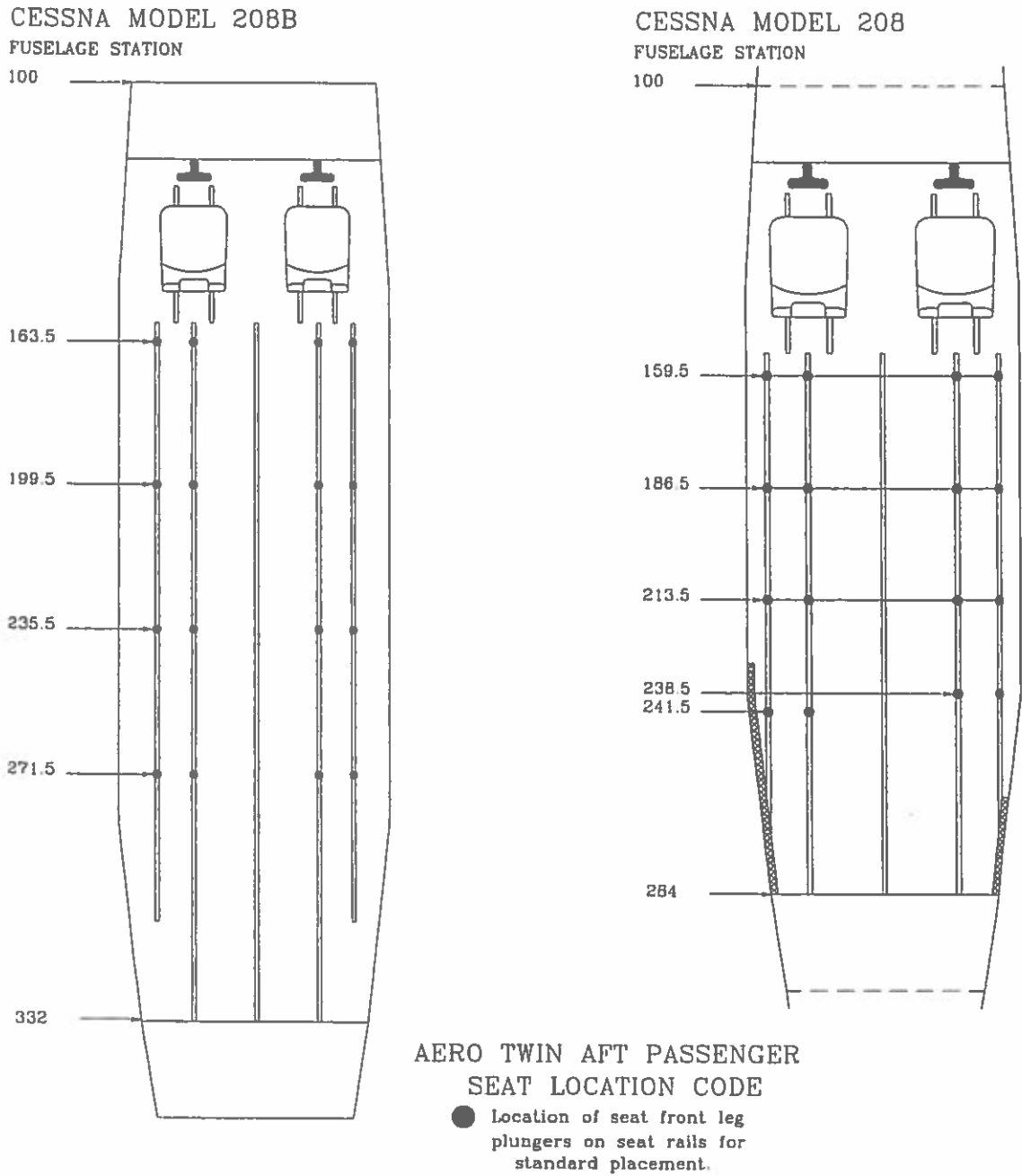

Figure 1.4.1. Standard Configuration Seat Locations

1.5 Maintenance Instructions

1.5.1 General:

The Aero Twin Single Place Folding Seat is designed to be highly durable and fairly maintenance free. However, a maintenance program has been established, in accordance with Appendix G of FAR 23, to assure the continued airworthiness of the seats. Adherence to the established plan is mandatory and records of performance of required inspections and maintenance must be maintained. See Section 2.0, Airworthiness Limitations, for required maintenance items and intervals.

1.5.2 Cleaning:

1.5.2.1 Upholstery:

- For general dust and light dry soiling, vacuum upholstery thoroughly, and or brush with a clean stiff bristle brush. Avoid beating fabric as this can hasten wear and does not effectively clean the upholstery. Use of commercially available upholstery shampoo will remove most soil encountered in normal service. Follow product directions.
- For oil or grease stains, solvent-type cleaning agents can be effective. Test a small inconspicuous area of the fabric first. Use solvent-type agents sparingly, without saturating fabric. Apply with a clean soft cloth and work from the edge of the stain towards the center to avoid spreading. Observe appropriate safety precautions when using any solvent agent.
- For heavy, saturating stains (coffee, vomit, etc.) the upholstery cover should be removed and commercially dry-cleaned.
- An optional seat slip cover is available, which provides an easily wipe able surface that can readily be removed from the seat for cleaning without major disassembly of the seat.

1.5.2.2 Herculite fabric (seat pan and seat back cover):

Clean the Herculite fabric components using mild soap and water solution or a commercial vinyl cleaner. For heavy grease or oil stains, a diluted solution of Simple Green or equivalent cleaning solution can be used. Avoid excessive wetting of the fabric when installed on the seat, as moisture can collect between the fabric and tube structure and promote corrosion.

1.5.2.3 Metal Parts:

Moisten a clean soft cloth with a solvent-type cleaner or undiluted Simple Green or equivalent; thoroughly wipe metal parts completely clean. Wipe dry with a clean dry cloth. After heavy cleaning over or near lubricated joints, relubricate as appropriate.

1.5.3 Lubrication and Corrosion Prevention:

The hinged leg connections to the seat frame and the sliding armrest sleeve on the upper diagonal arms (when optional armrests are installed) are areas that must be kept well lubricated and protected from moisture. *Corrosion X*™ is a product that is well suited to this dual purpose. This product is available from Aero Twin, Inc., or your local aviation supplier. Other commercial products are available that will perform well. WD-40 is not recommended, as its moisture displacement properties are inadequate.

The required maintenance procedures for the seat include lubrication and internal treatment of the steel tubes at specific intervals. The seat should also be lubricated if it is subjected to heavy moisture for any reason, or after thorough cleaning of the metal frame.

- To lubricate the rotating and sliding joints, spray lubricant into the joint while rotating or sliding the fitting (avoid overspray on the upholstery cover by first pulling the cover back from the joint). Wipe off all excess lubricant with a clean dry cloth.
- To internally treat the steel tubes, the upholstery cover and Herculite fabric seat pan and seat back cover should be removed. Using a small nozzle, spray *Corrosion X™* (or equivalent) into all available holes. Allow the frame to sit for several minutes to allow excess to drain as it may, then wipe off all external surfaces with a clean, dry cloth. Reassemble seat.

If the painted surface of the steel tube structure is marred in service or during handling, the affected area should be repainted to prevent corrosion. See instructions in section 1.5.5.3.

1.5.4 Disassembly / Assembly:

1.5.4.1 Disassembly:

- To remove the padded upholstery cover, the shoulder harness must be removed. Access to the clevis bolt head is through the opening in the upholstery cover at the bottom of the seat back. When optional armrests are installed, the upper diagonal arms must also be removed to remove the upholstery cover (disconnect from the eyebolts in the seat back frame). Pull the cover bottom free from the hook-and-loop strips on the seat pan, then slide the cover up and off the seat back.
- To remove the Herculite seat back cover, loosen and release the strap buckles on the aft side of the seat, then slide the cover off of the seat back frame.
- To remove the Herculite seat pan, remove the sheet metal screws from the underside of the seat frame.
- Disassembly of the seat frame is straightforward, as all connections utilize standard aircraft hardware.

1.5.4.2 Assembly:

Refer to the Illustrated Parts List when reassembling the seat frame.

Replace self-locking type nuts with new hardware when reassembling seat.

Any time the Herculite seat pan is removed, use new screws for reinstallation.

Use standard torques except as follows:

- The nuts on the seat back hinge bolts, which retain the lap belts, should be snug but not over-tight to allow rotation of the seat back and the lap belt fittings.
- The nuts on the clevis bolts at the upper ends of the four diagonal arms, and the nuts that retain the four eyebolts to which the arms attach, should be snug but not over-tight to allow rotation of the arms for folding.

- The nuts and bolts which attach the feet (seat track fittings) to the eyebolts at four locations should not be tightened so much as to cause distortion of the cast lugs on the fitting.

Remember that the padded upholstery cover, when utilized, must be installed prior to installation of the shoulder harness and armrests (when armrests are not present, the upper diagonal arms can be installed prior to the cover).

1.5.4.3 Adjustments:

- Upper Diagonal Arms: The length of these is adjustable by turning the lower end fitting in or out on the integral stud. Maximum acceptable length is 16.6 inches for seats prior to ATFS1-01 S/N 1600 or ATFS1-01S S/N 638 and 16.9 for newer seats - **do not exceed this length when making adjustments to these assemblies.**
- Lower Diagonal Arms: These members are not adjustable, but minor adjustments can be made at the stud (item -109) in the forward leg assembly. Maximum allowable extension is that which produces a gap of 0.20 inch between the top of the welded nut on the leg and the bottom of the hex-head on the stud - **do not exceed this measurement.**
- **Do not** attempt to adjust the height of the rear legs by turning out the eyebolts to which the feet are attached. Need for such adjustment indicates warpage elsewhere in the seat frame which should be corrected.

1.5.5 Repair:

1.5.5.1 Hardware Replacement:

Hardware and fittings used throughout the seat are aircraft standard. Hardware should be replaced if corroded, damaged, or excessively worn. Replace self-locking type nuts with new hardware when reassembling seat. Do not substitute hardware - refer to the Illustrated Parts List for correct part numbers. If you encounter difficulty procuring replacement hardware or fittings, contact Aero Twin, Inc. at (907) 274-6166. Refer to previous section for assembly information.

1.5.5.2 Steel Tube Frame:

The seat frame is of welded 4130 steel tube (MIL-T-6736) construction and can be repaired in accordance with the procedures prescribed in AC 43.13-1A Chapter 2, Section 2 (see note below). Any welded repair should be preceded by stripping the paint from the affected area, and followed by repainting to prevent corrosion (see following section). Care should be taken to avoid warping or drawing when performing welding operations on the seat. Excessive warping can result in difficult assembly and installation, and detrimental preloads in an installed seat.

NOTE: Lower diagonal arms, P/N ATFS-85 or P/N ATFS-85S and upper diagonal arms P/N ATFS-95 or DFS1-95, are not eligible for repair. If these parts are found to be bent or cracked, they must be discarded and replaced. Refer to Airworthiness Limitations in Section 2.0 of this manual.

1.5.5.3 Painted Surfaces:

Painted steel surfaces should be maintained and refinished as required to prevent corrosion. When refinishing is required, lightly sand the affected area using fine sandpaper or an abrasive pad (such as 3M *Scotch-Brite*™). Polish out minor surface nicks or scratches where present. Clean the area thoroughly with a clean cloth wetted with non-petroleum-based solvent to remove any residual oils and dust. Apply a zinc-chromate or equivalent primer coat, then a matching color coat of quality enamel or epoxy-type paint. Follow manufacturer's instructions in preparing and applying primer and color coats.

1.5.5.4 Fabric:

- **Herculite Components:** These components are subject to mandatory replacement at fifteen-year intervals, but should be replaced when found to be excessively worn, frayed, or torn. Open seams can be restitched using nylon thread.
- When replacing the Herculite seat pan with a new assembly:
 - Ensure that metal strips in edge are positioned in their pocket with the outside edge against the fold of the pocket.
 - Position the seat pan on the metal frame with the existing screw holes centered in both the metal strips and the nylon webbing.
 - Match drill the seat pan to the existing screw holes using a #32 drill bit and secure the pan to the frame using S1021A6-8 or MS51863-23C screws.
- **Upholstery:** Restitch open seams using nylon thread. Small tears can be drawn closed and sewn. Extensive damage usually justifies replacement of the upholstery cover.

1.5.5.5 Restraint Belts:

The belt assemblies are subject to mandatory replacement at twelve-year intervals. Worn, frayed, cut, or otherwise damaged belt assemblies should be replaced or remanufactured immediately by a qualified repair station. Any belt assembly that is found to be missing its manufacturer's data patch must be considered unairworthy and must be replaced.

1.5.5.6 Seat Feet:

The seat track fittings that serve as seat feet use a plunger that slides up and down on a steel body and locks into the seat track when pushed down. A retaining pin is in the front of the body that is pushed out by a small spring to sit in a groove inside the plunger. The pin keeps the plunger from falling off the bottom of the body. Sometimes the plunger can be jarred out of place and the pin, spring, and ball that the spring seats on are lost. A repair kit, ATI-40566-R, is available, which provides replacement pins, springs, and balls. Later seat feet incorporate a roll pin to further restrict the plunger from falling off the bottom of the body.

2.0 Airworthiness Limitations

Aero Twin, Inc. Single Place Folding Seat P/N ATFS1-01 standard version P/N ATFS1-01S flightseeing version

The Airworthiness Limitations section is FAA approved and specifies maintenance required under paragraphs 43.16 and 91.403(c) of the Federal Aviation Regulations unless an alternative program has been FAA approved.

This section describes required inspection, maintenance, and replacement items. When repairs are deemed necessary, follow accepted standard practices and/or specific maintenance instructions in Section 1.5 of this manual.

This section constitutes Component Airworthiness Limitations which apply to the seat only.

2.1 Scheduled Inspections and Maintenance:

Note: First inspection should be accomplished at next aircraft inspection so that subsequent inspections coincide.

2.1.1 1,000 hour or Annual Inspection:

Remove padded upholstery cover.

Inspect steel tube frame:

Tubes for bends, dents, corrosion, or other defects.

Welded areas for cracks or other defects.

Finish for scratches, abrasion, etc.

Inspect hardware and fittings:

Hardware for security and condition.

Quick-release fittings for proper operation and condition.

Feet (track fittings) for proper operation, security, and condition.

Inspect Herculite fabric (seat pan and seat back cover):

Fabric for wear, fraying, tearing, or other defects

Attachment screws (seat pan) for security

Straps and buckles (seat back) for condition and tautness

Inspect restraint system (lap belts and harness):

Webbing for cuts, fraying, or other defects.

End fittings for security and condition.

Buckles for proper operation.

Data patches (must be present and legible).

Inspect overall seat assembly and upholstery for cleanliness and general airworthiness.

Lubricate all rotating and sliding parts fittings (Corrosion X™ or equivalent).

Reinstall padded upholstery cover.

FAA Approved: _____

Date: 2/1/13

2.1.2 Five-Year and Ten-Year Inspection:

Remove padded upholstery cover.

Remove Herculite seat pan and seat back cover.

Inspect steel tube frame:

All welded joints using a 10X glass for cracks.

(Strip paint from area around any apparent crack and re-inspect).

Treat all tubing internally with corrosion preventative (*Corrosion A™* or equivalent).

Complete all items for a **1000 Hour / Annual Inspection**.

Reinstall seat pan using new screws; reinstall seat back cover and upholstery cover.

2.1.3 Fifteen-Year Inspection:

Remove padded upholstery cover.

Remove Herculite seat pan and seat back cover and discard.

Disassemble seat frame.

Strip paint from all welded joints and inspect using a 10X glass.

Complete all items for a **5/10-Year Inspection**.

Repaint seat frame components.

Reassemble seat frame using new hardware.*

Install NEW Herculite seat pan and seat back cover.*

Reinstall padded upholstery cover.

*A kit containing all parts necessary to complete these steps is available from Aero Twin, Inc. Call (907) 274-6166, or visit www.aerotwin.com to order Kit No. ATFS1-II.

2.1.4 Restraint Belt Restrictions:

In addition to the above inspection schedule, the restraint belt assembly must be replaced every 12 years per the restraint belt manufacturer's limitations.

2.2 Mandatory Replacement:

Herculite seat back cover and seat pan, P/N ATFS1-06(T) and ATFS1-07A (ATFS1-07B after ATFS1-01 S/N 1599 or ATFS1-01S S/N 637) respectively, must be replaced by new parts during 15 year inspection as discussed in 2.1.3.

Restraint belt assembly, P/N 5-01-820701, must be replaced every 12 years as discussed in 2.1.4.

FAA Approved: _____

Date: _____

-----End of Section 2.0 Airworthiness Limitations-----

3.0 Illustrated Parts List

P/N ATFS1-01 and P/N ATFS1-01S

3.1 Complete Parts List:

Item	Qty	Part Number	Description	Appears on Fig:
-01	2	MS24665-132 (S/N 1600 and on)	Cotter Pin	3.5
-02	2	ATFS-02A or ATFS-02SA	Complete Lower Arm Assembly	3.5
-03	2	ATFS-03A (thru S/N 1599) DFS1-03 (S/N 1600 and on)	Complete Upper Arm Assembly	3.3
-04	1	ATFS1-04 or ATFS1-04T	Seat Back Weldment	3.3
-05	1	ATFS1-05 or ATFS1-05S	Seat Bottom Weldment	3.5
-06	1	ATFS1-06 or ATFS1-06T	Back Rest Cover Assembly	3.3
-07	1	ATFS1-07A (thru S/N 1599) ATFS1-07B (S/N 1600 and on)	Seat Bottom Cover Assy	3.6
-08	2	MS20392-3C35 (S/N 1600 and on)	Clevis Pin	3.5
-62	4	ATFS-62L	Eye Bolt	3.5, 3.6
-85	2	ATFS-85A or ATFS-85SA	Lower Arm Weldment	3.2
-95	2	ATFS-95A (thru S/N 1599) DFS1-95 (S/N 1600 and on)	Upper Arm Weldment	3.2
-95 alt.	(2)	ATFSAR-A	Upper Arm w/Armrest	3.2
-100	AR	NAS1149F0532P	Washer	3.3, 3.4, 3.5, 3.6
-101	16	MS21083N5	Nut	3.3, 3.4, 3.5, 3.6
-102	4	AN25-14A or AN5-10A	Bolt	3.3, 3.5
-103	4	AN5-11A	Bolt	3.6
-104	2	MS22034-1	Retainer	3.2
-105	2	AN316-6R	Nut	3.2
-106	2	SS-1004 (thru S/N 1599) ATFS-106 (S/N 1600 and on)	Retainer (Sub-Assy)	3.2
-108	4	ATI-SFT-14 OR -15	Retainer (Foot; Track Fitting)	3.6
-109	2	ATFS-109	Fitting (stud)	3.6
-110	2	NAS561P8-16	Pin	3.2
-111	2	AN45-12A or ATFS-62L	Eye bolt	3.3
-112	1	MS21083N4	Nut	3.4
-113	2	ATFS-113 (thru S/N 1599)	Ball Stud	3.5
-115	2	ATFS-115A	Flanged Bushing	3.4
-117	4	AN5-7A	Bolt	3.4
-119	AR	NAS1149F0563P	Washer	3.4
-120	1	AN24-24A	Bolt	3.4
-121	1	S1003-9A	Bushing	3.4
-122	AR	NAS1149F0463P	Washer	3.4
-123	1	5-01-820701	3-Point Restraint Assembly	3.4
-131	22	S1021A6-8 or MS51863-23C	Screw	3.6
Accessories:				
N/A	Optional	ATFS1-34T(U)	Back Rest Cushion (Upholstered)	(not shown)
N/A	Optional	ATFS1-35(T) or (U)	Seat Pan Cushion (Thin) or (Upholstered)	(not shown)
N/A	Optional	ATFS1-08 or ATFS1-08T	Padded Upholstery Cover	(not shown)
N/A	Optional	ATFS1-SC or ATFS1-SCT	Seat Slip Cover	(not shown)
N/A	Optional	ATFS1-09	Storage Bag	(not shown)
N/A	Optional	AT-SRT-01	Removal Tool	(not shown)
N/A	N/A	AT-40566-R	Seat Foot Repair Kit	(not shown)

Figure 3.1

*S/N's shown in Figures 3.1 thru 3.6 are for P/N ATFS1-01. For P/N ATFS1-01S, new upper arm configuration is used on S/N 638 and on.

3.2 UPPER AND LOWER ARM ASSEMBLIES

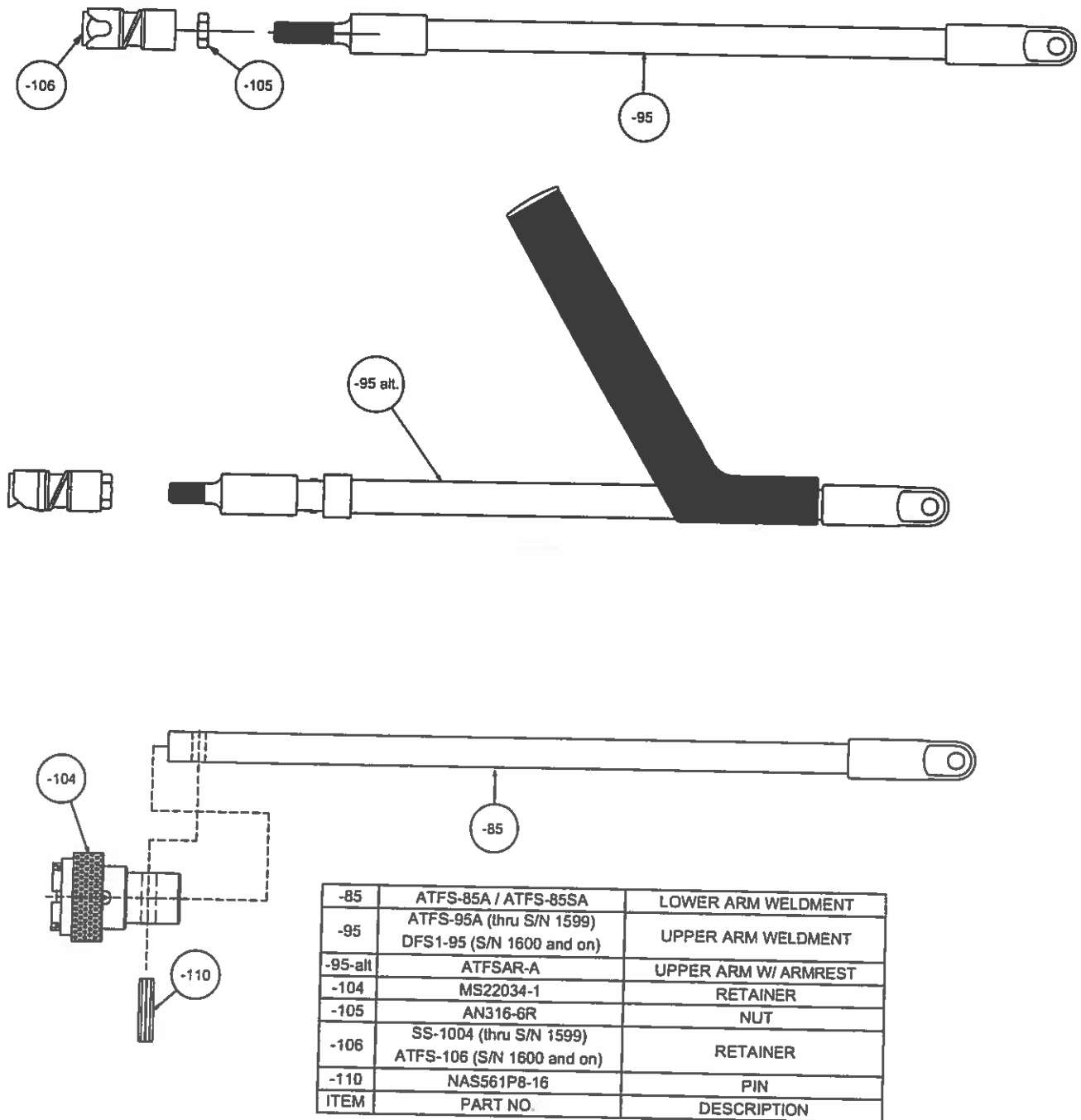
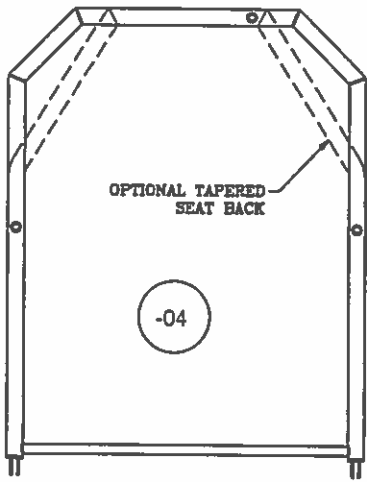
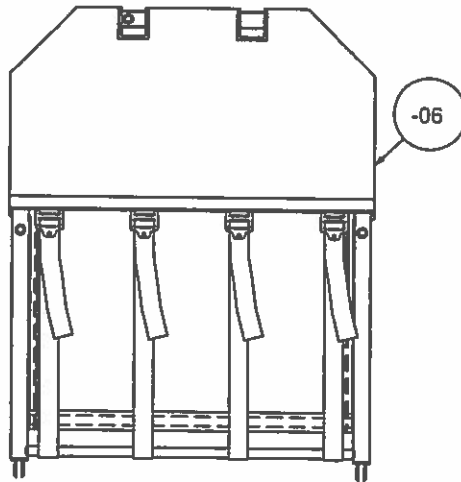

FIGURE 3.2

3.3 BACK REST COVER AND UPPER ARM INSTALLATION



PN ATFS1-04, SEAT BACK ASS'Y WELDMENT



INSTALLED BACK REST COVER REAR VIEW

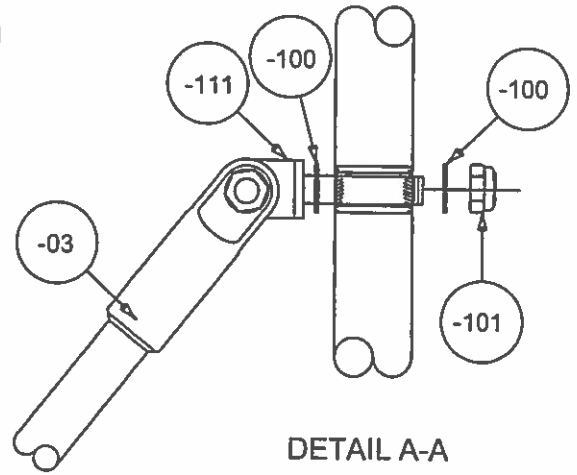

DETAIL A-A
(TYP. OF 2 PL.)

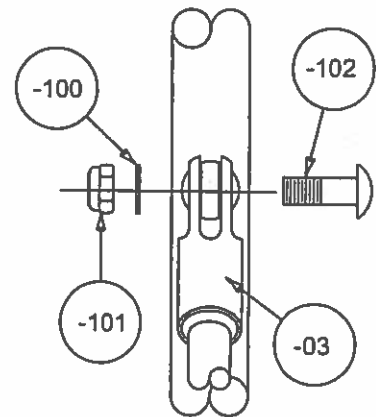
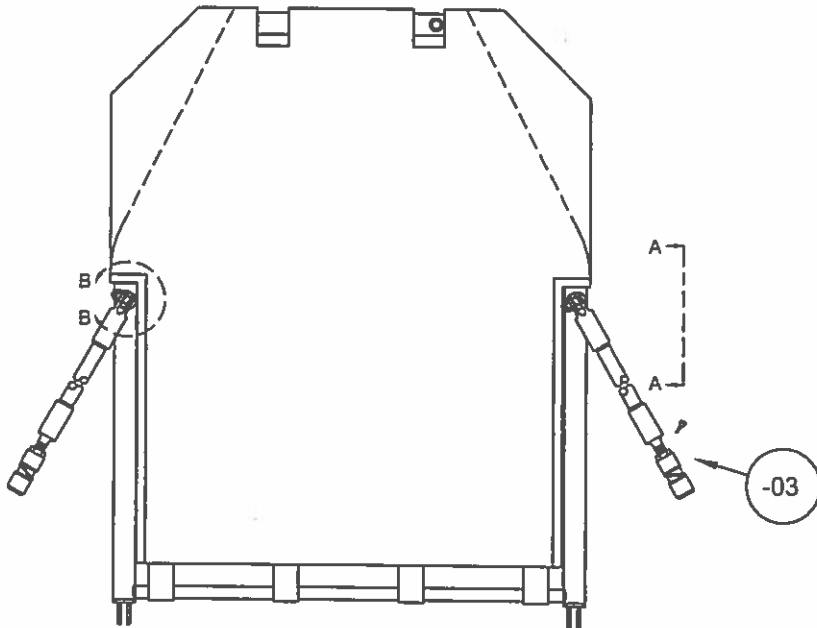

DETAIL B-B
(TYP. OF 2 PL.)

-03	ATFS-03A (thru S/N 1599) DFS1-03 (S/N 1600 and on)	UPPER ARM ASSEMBLY
-04	ATFS1-04 or ATFS1-04T	SEAT BACK WELDMENT
-06	ATFS1-06 or ATFS1-06T	BACK REST COVER ASS'Y
-100	NAS1149F0532P	WASHER
-101	MS21083N5	NUT
-102	AN25-14A or AN5-10A	BOLT
-111	AN45-12A OR ATFS-62L	EYE BOLT
ITEM	PART NO.	DESCRIPTION

FIGURE 3.3

3.4 SEAT BACK, LAP BELT, AND HARNESS INSTALLATION

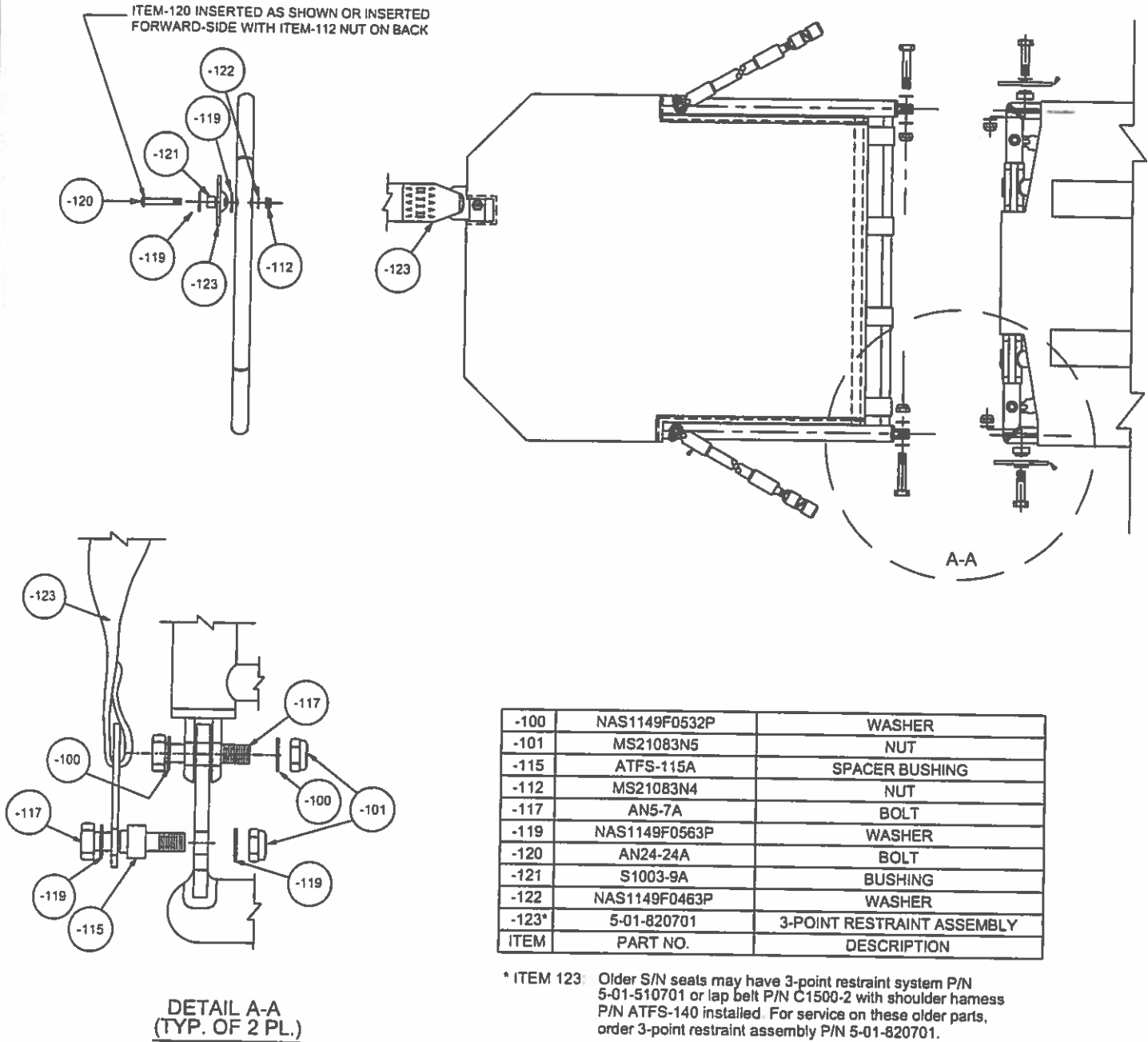

FIGURE 3.4

3.5 SEAT BOTTOM HARDWARE & LOWER ARM INSTALLATION

-01	MS24665-210	COTTER PIN
-02	ATFS-02A	COMPLETE LOWER ARM ASSY
-05	ATFS1-05	SEAT BOTTOM WELDMENT
-08	MS20392-3C35	CLEVIS PIN
-62	ATFS-62L	EYE BOLT
-100	NAS1149F0532P	WASHER
-101	MS21083N5	NUT
-102	AN25-14A or AN5-10A	BOLT
-113	ATFS-113	BALL STUD
-122	NAS1149F0463P	WASHER
ITEM	PART NO.	DESCRIPTION

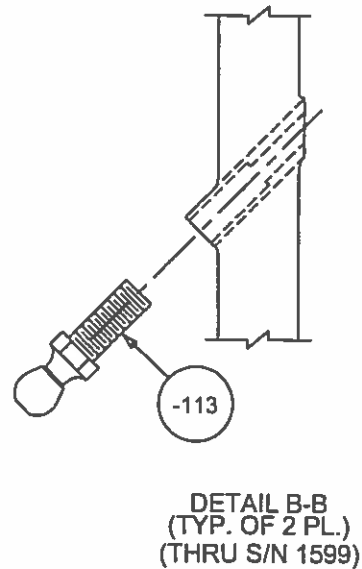
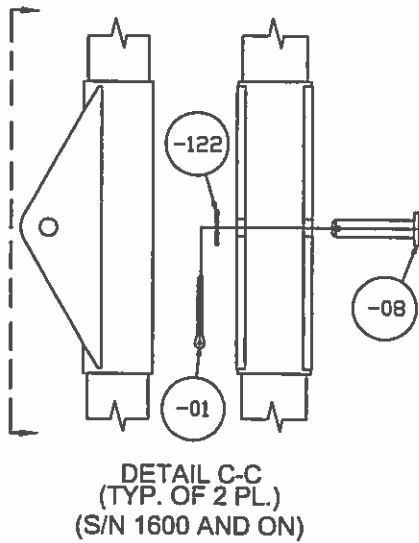
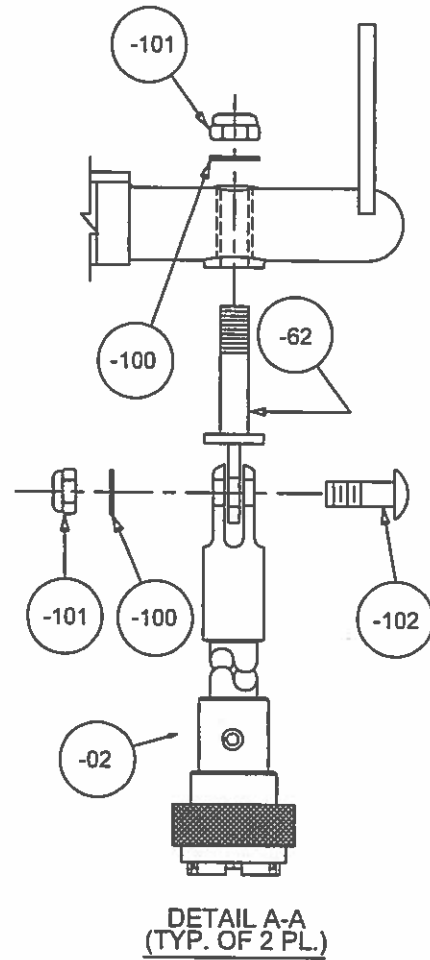
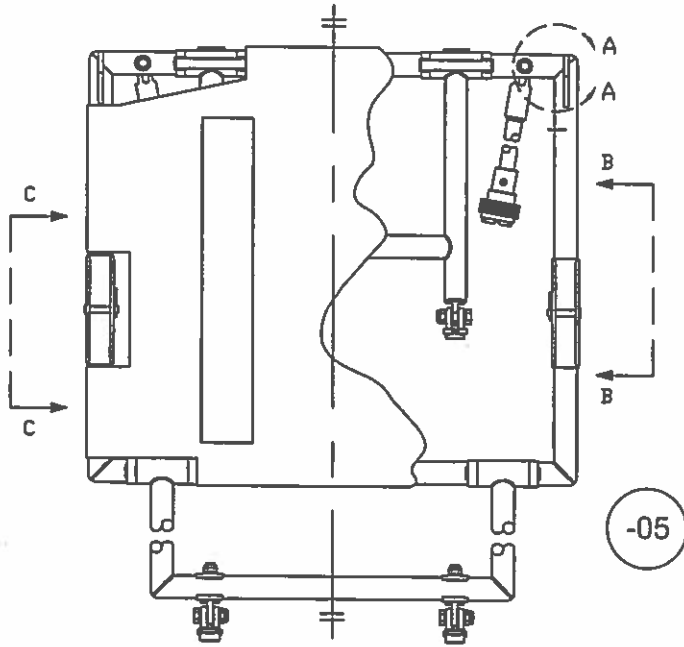

FIGURE 3.5

3.6 SEAT BOTTOM COVER AND FOOT INSTALLATION

-07**	ATFS1-07A** ATFS1-07B**	SEAT BOTTOM COVER ASSY
-62	ATFS-62L	EYE BOLT
-100	NAS1149F0532P	WASHER
-101	MS21083N5	NUT
-103	AN5-11A	BOLT
-108*	ATI-SFT-14 OR -15*	RETAINER (FOOT)
-109	ATFS-109	FITTING
-131	S1021A6-8 or MS51863-23C	SCREW
ITEM	PART NO.	DESCRIPTION

**THRU S/N 1599 USE ATFS1-07A (SHOWN),
S/N 1600 AND ON USE ATFS1-07B.

*IF OPTIONAL P/N ATI-SFT-15 IS USED, ADD ITEM -100 WASHERS
SYMMETRICALLY BETWEEN EYE BOLT AND ITEM -108 AS NECESSARY
TO REMOVE EXCESSIVE SLOP IN THE RETAINER ATTACHMENT.

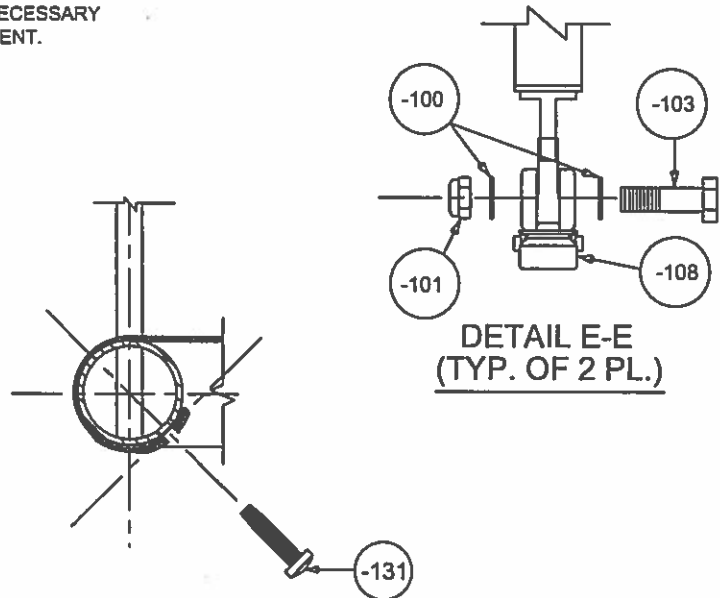
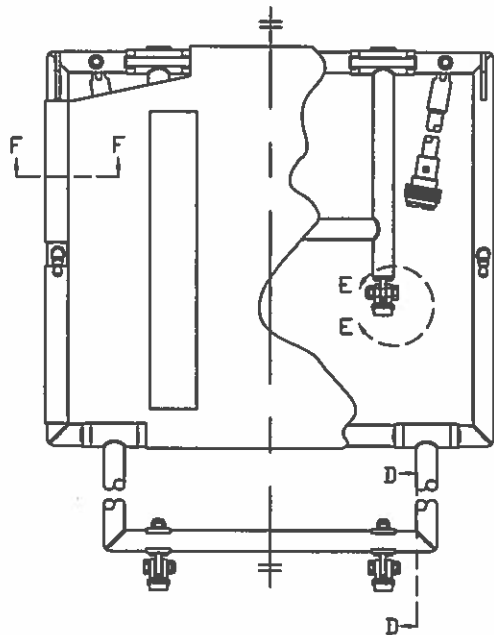

DETAIL F-F
(TYP. OF 20 PL. THRU S/N 1599)
(TYP. OF 18 PL. S/N 1600 AND ON)

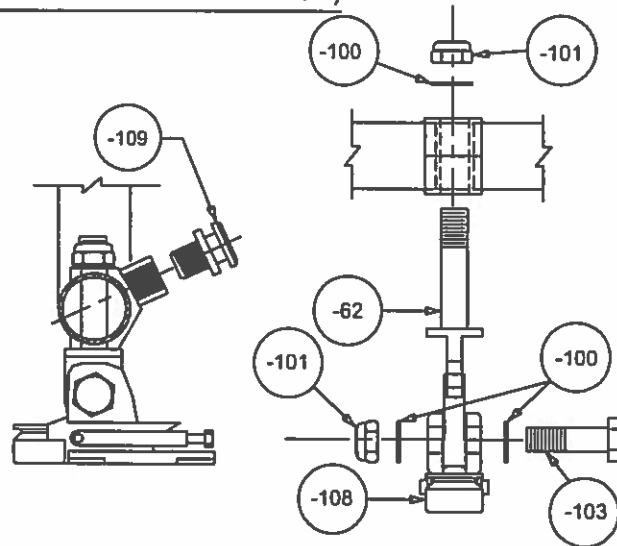
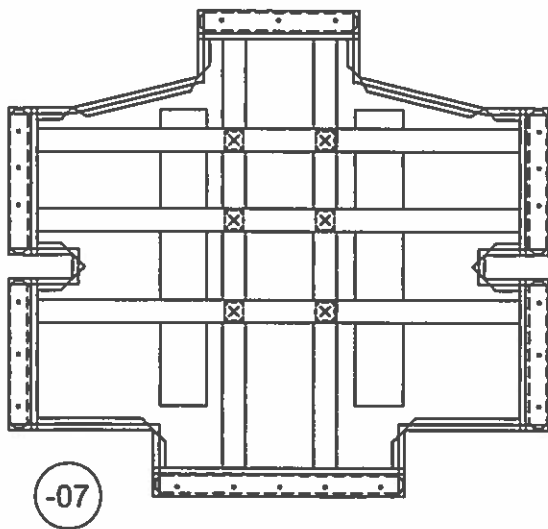

DETAIL D-D
(TYP. OF 2 PL.)

FIGURE 3.6